

---

# AquaWorker

## Installation, Operation and Service Manual

---

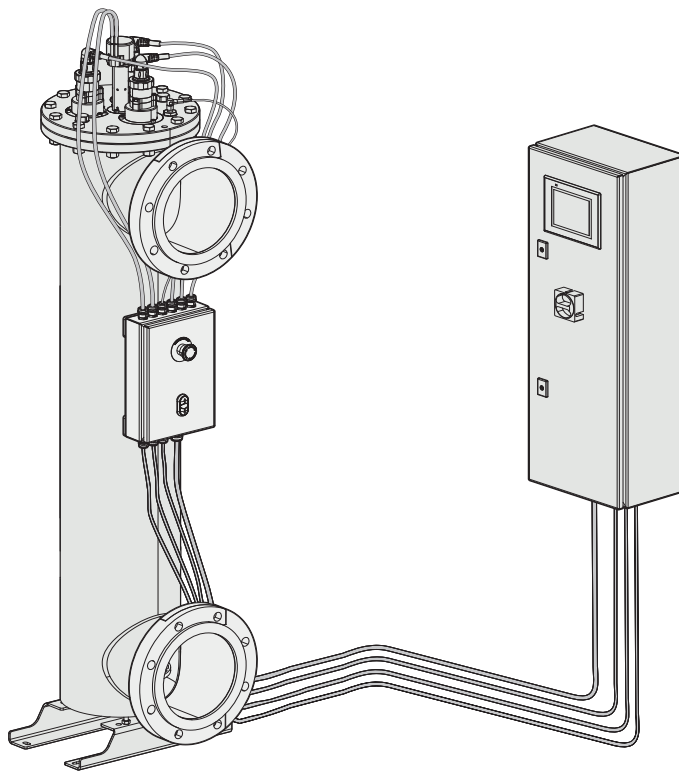

en Original instructions

**WALLENIUS**  
**WATER** INNOVATION

# Table Of Contents

---

<b>1 General</b> .....	<b>1</b>
1.1 Disclaimer .....	1
1.2 Warranty .....	1
1.3 Manufacturer .....	2
1.4 Service and support .....	2
1.5 Disposal .....	2
1.6 Acronyms and abbreviations .....	2
<b>2 Safety</b> .....	<b>3</b>
2.1 Warning, caution, and notes .....	3
2.2 General safety rules .....	3
<b>3 Transportation</b> .....	<b>5</b>
3.1 Unpacking .....	5
3.2 Delivery inspection .....	6
<b>4 System Description</b> .....	<b>7</b>
4.1 AquaWorker - for disinfection of water .....	7
4.2 Functional description .....	7
4.3 Control system .....	7
4.4 System overview .....	8
<b>5 Installation</b> .....	<b>10</b>
5.1 Before installation .....	10
5.2 Connecting the AquaWorker .....	13
5.3 Install UV-lamps .....	15
5.4 Electrical installation .....	17
<b>6 Operation</b> .....	<b>19</b>
6.1 Important instructions .....	19
6.2 Starting up .....	20
6.3 Turning off .....	22
<b>7 Service and Maintenance</b> .....	<b>23</b>
7.1 Quartz sleeve cleaning .....	24
7.2 Lamp replacement .....	29
7.3 Cleaning system service .....	33
7.4 Quartz sleeve replacement .....	36
7.5 Bearing and sealing service .....	41
7.6 Replacing lead screw nut .....	46
7.7 Draining the AquaWorker .....	53
7.8 Filling and bleeding the AquaWorker .....	54
<b>8 Uninstall</b> .....	<b>55</b>
8.1 Uninstalling the system .....	55
<b>9 Troubleshooting</b> .....	<b>56</b>
9.1 Alarm list .....	56
<b>10 Spare parts</b> .....	<b>58</b>
10.1 Spare parts list .....	59
<b>11 Specifications</b> .....	<b>62</b>
11.1 Technical specifications .....	62
11.2 Dimensions .....	64
11.3 Tightening torque .....	65
<b>A Appendix</b> .....	<b>66</b>
A.1 Automatic control system .....	66
A.2 Site acceptance test (SAT) .....	74
A.3 Maintenance Record .....	77
A.4 Connection terminal list .....	78
A.5 Electrical drawings .....	80
50-0040 Cabinet layout_1 .....	81
50-0040 Cabinet layout_2 .....	82

---

50-0039 Main Power_1 .....	83
50-0039 Main Power_2 .....	84
50-0043 Electrical connections .....	85
50-0044 Juntion box layout .....	86
50-0039 PLC_I_O .....	87
<b>Declaration of Conformity .....</b>	<b>88</b>

# 1 General

Please read this manual carefully prior to installation and operation of the unit. Save these instructions for future use.

## 1.1 Disclaimer

Wallenius Water Innovation AB is not liable or bound by warranty if these instructions are not adhered to during installation, operation or service.

Wallenius Water Innovation AB reserve the right to make changes to components, specifications and modify the contents of the documentation without further notice.

Wallenius Water Innovation AB only guarantees correct function of the unit with original or specified components.

The AquaWorker is intended for use of water treatment only. Any other use is prohibited.

## 1.2 Warranty

Wallenius Water Innovation AB warrants that this product will be free from defects in material and workmanship for a period of one year from the date of delivery thereof.

Within the warranty period Wallenius Water Innovation AB will repair or replace such products and component parts which are returned to Wallenius Water Innovation AB with shipping charges prepaid and which are determined by Wallenius Water Innovation AB to be defective.

This warranty will not apply to any product or component part which has been subjected to misuse, negligence or accident; or misapplied; or modified or repaired by unauthorized persons or not installed according to specification given in this manual.

Any attempt to change or modify existing equipment with non-original components invalidates the warranty.

Consumable products (UV-lamps and quartz sleeves) have a warranty period of 3 months from delivery date.

Buyer shall inspect the product promptly after receipt and shall notify Wallenius Water Innovation main office in writing of claims, including claims of breach of warranty, within thirty days after the buyer discovers or should have discovered the facts upon which the claim is based.

Failure of the buyer to give written notice of a claim within the time period shall be deemed to be a waiver of such claim.

## 1.3 Manufacturer

Wallenius Water Innovation AB

[www.walleniuswater.com](http://www.walleniuswater.com)

## 1.4 Service and support

For any support issues, please contact Wallenius Water Innovation AB through:

e-mail: [support@walleniuswater.com](mailto:support@walleniuswater.com)

telephone: +46 8 120 138 10 during office hours

fax: +46 8 522 722 99

## 1.5 Disposal

Always consult local rules and regulations for correct handling of each material:

- Used UV-lamps can be handled and recycled in the same way as fluorescent lamps.
- Used quartz sleeves can be recycled in the same way as recyclable glass
- Used cartridges can be recycled as plastic

## 1.6 Acronyms and abbreviations

### **LPS**

Lamp Power Supply

### **HMI**

Human Machine Interface.

This is the operation control, the touch display placed on the control cabinet.

### **PLC**

Programmable Logic Controller.

This means the computer that calculates actions in the system, this unit is placed inside the control cabinet.

## 2 Safety

### 2.1 Warning, caution, and notes

<b>WARNING</b>	Indicates a potentially hazardous situation which could result in death or severe injury.
<b>CAUTION</b>	Indicates a potentially hazardous situation which could result in property damage.
<b>NOTE</b>	A note is used to notify people of installation, operation or maintenance information which is important but not hazard related.

### 2.2 General safety rules

This chapter contains the safety instructions which you must follow when installing, operating and servicing the system. If ignored, physical injury or death may follow, or damage may occur to the drive, the motor or driven equipment.

<b>WARNING</b>	<b>UV-radiation can instantly harm eyes and skin, never look into a burning lamp! Always use necessary protective equipment (such as protective glasses and gloves) when working with the UV-lamps.</b>
<b>WARNING</b>	<b>Do not operate the AquaWorker in explosive environments.</b>
<b>CAUTION</b>	<b>This equipment must be installed by authorized installation technicians and the installation must adhere to applicable local rules and regulations as well as these installation instructions.</b>
<b>CAUTION</b>	<b>Make sure the installation conditions meets the technical specification described in this manual (e.g. electrical input).</b>
<b>CAUTION</b>	<b>The AquaWorker must be mounted on a rigid and solid wall or stand.</b>

**CAUTION**

Never use the cords for carrying or pulling the AquaWorker.

**CAUTION**

Do not operate the AquaWorker without water in the system.

**CAUTION**

UV-lamps and quartz sleeves are fragile components, please handle these components with care.

## 3 Transportation

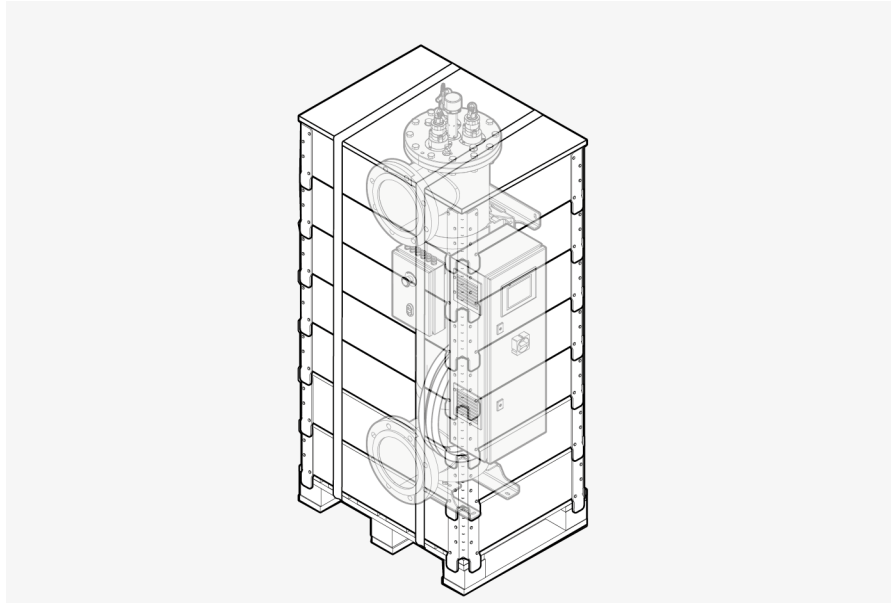

The AquaWorker is placed on a half euro pallet to maintain a small footprint.

When the AquaWorker is shipped it will come in one unit.

The UV lamps and loose flanges are delivered in separate packaging on the pallet during transportation, all other parts are assembled.

### 3.1 Unpacking

Check that there are no transportation damages.

Remove the pallet collars from the pallet.

Remove the electrical cabinet from its temporary attachment.



## 3.2 Delivery inspection

### **CAUTION**

**Do not touch the new lamps or sleeves with bare hands.  
Use protective gloves!  
Fingerprints on the lamps may impair the intensity  
of the light.**

Check the AquaWorker in general for any damages. Especially check the UV lamps and quartz sleeves for damages.

Use the packing list and tick-off accordingly.

If something is missing or if any part of the AquaWorker, the UV lamps or the quartz sleeves are damaged - contact your distributor.

Notify Wallenius Water Innovation office immediately if damages are found.

## 4 System Description

### 4.1 AquaWorker - for disinfection of water

AquaWorker is based on a water purification technology that imitates nature's own way of degrading microorganisms.

AquaWorker has been developed specifically for water disinfection in salt and fresh water systems. All materials in contact with water are corrosion resistant.

### 4.2 Functional description

AquaWorker consists of a reactor and a control system.

A thermo switch (bi-metal) registers the water temperature and switches off the lamps if the water temperature in the reactor gets too high.

### 4.3 Control system

The control system continuously monitor correct operation and trigger alarm at any operational fault. The AquaWorker is managed through a 5.7" colour touch screen mounted on the control panel.

For more information regarding the control system, see Appendix - "Automatic control system" on page 66.

## 4.4 System overview

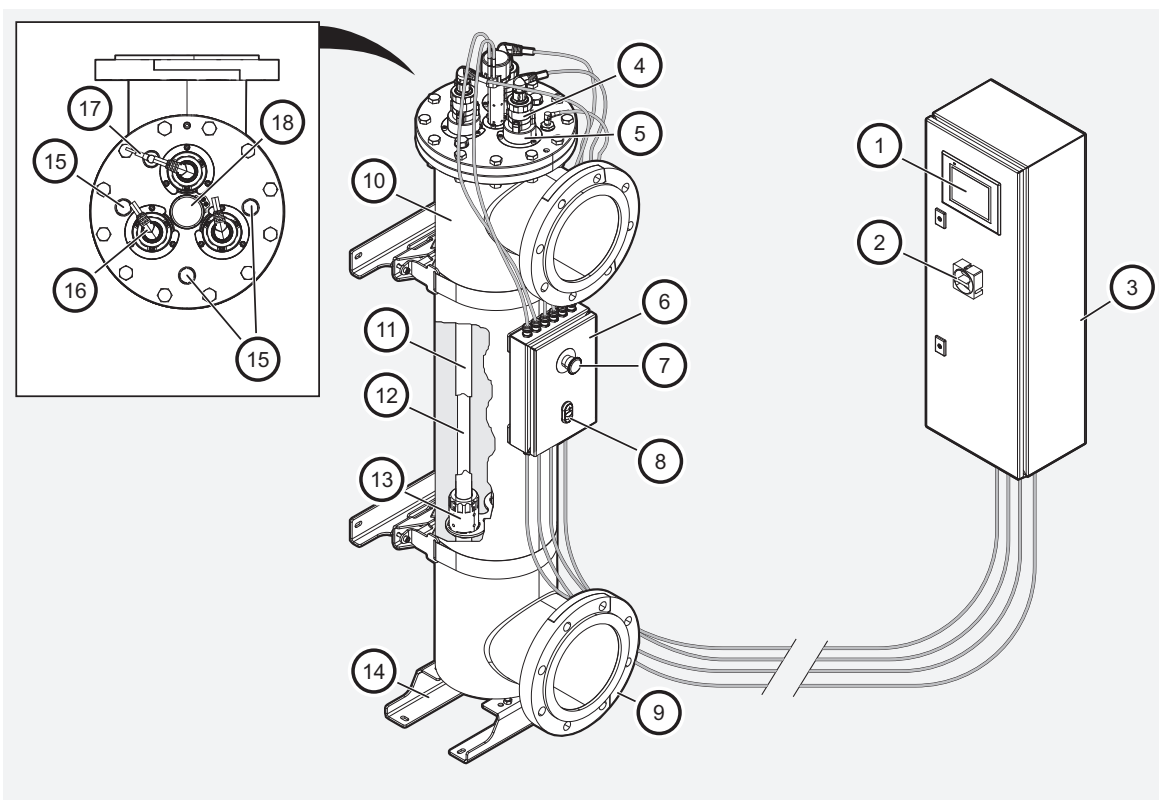

Position	Description
1	Touch display. 5.7" colour touch screen (HMI)
2	Main switch. The main power switch for the AquaWorker.
3	Electrical cabinet. Main control unit including LPS (Lamp Power Supply).
4	Lamp top. UV-lamp electrical interface.
5	Quartz sleeve holder
6	Terminal box. Secondary control unit. Cable connection box.
7	Safety switch for emergency shut down.
8	Up/Down service buttons for maneuvering of the cleaning system (AW310/330).
9	Connection flanges
10	Reactor
11	Quartz sleeve

Position	Description
12	UV-lamp
13	Cleaning system (AW310/330)
14	Stand
15	Drain/aeration positions
16	Lamp connector
17	Thermo switch
18	Motor for the AquaWorker cleaning system (AW310/330).

## 5 Installation

### NOTE

Depending on installation requirements, different lengths of cables between the control panel and the reactor is possible to order. Cable length max 30 m.

The installation process for the AquaWorker is divided into these steps:

- Before installation
- Mechanical installation
- Electrical installation
- Site acceptance test (SAT)

### 5.1 Before installation

### CAUTION

Read "Specifications" on page 62 carefully before installation.

- Make sure that the general safety rules are applied. See "Safety" on page 3 - General safety rules.
- Make sure that all installation requirements are within the technical specifications of the unit, see "Specifications" on page 62.
- Thoroughly clean the system, in which the AquaWorker will be installed, to get the best result.
- The AquaWorker must be mounted on a rigid and solid wall or stand.
- It is recommended that the inlet pipe is straight, not curved, at least 1000 mm before entering the reactor.
- From factory, all screws are fixated with correct torque (see "Tightening torque" on page 65). It is however recommended that the screws are checked before start-up.
- Make sure that reactor is filled with water, see "Insufficient water level" on the next page.

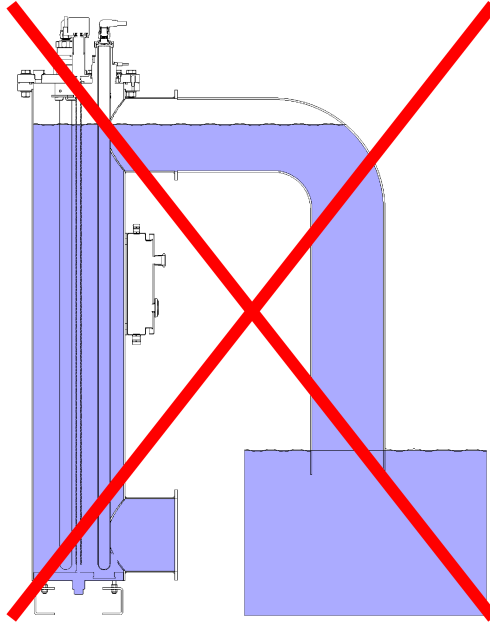

*Insufficient water level*

Special attention must be taken in installations where the system flow and downstream pressure loss is very low. To avoid flow conditions as shown in the illustration, ensure that the whole reactor volume is filled with water. To completely fill the reactor, it is required that control of the flow and pressure loss is handled downstream from the AquaWorker. Preferably, this is achieved by constructing siphon piping downstream already in the design phase.

### 5.1.1 Tools and equipment required for installation

Description	Note
Wrench	13 mm for fixating straps (only horizontal positioning)
Wrench	16 mm to adjust the feet (M10)
Wrench	24 mm for top flange bolts (M16)
Wrench	27 mm for plugs (aeration, drainage), thermo switch and lower bearing housing
Wrench	30 mm for flange bolts (M20)
Allen key	2,5 mm for M3 screw
Allen key	4 mm for M5 screws
Allen key	5 mm for M6 screws
Allen key	6 mm for M8 screws
Protective gloves	Use clean protective gloves (when inserting lamps)
Gasket	To seal the flange connection
Bolts	To fasten the AquaWorker to the piping system

## 5.2 Connecting the AquaWorker

**NOTE**

See Appendix - "Tightening torque" on page 65 .

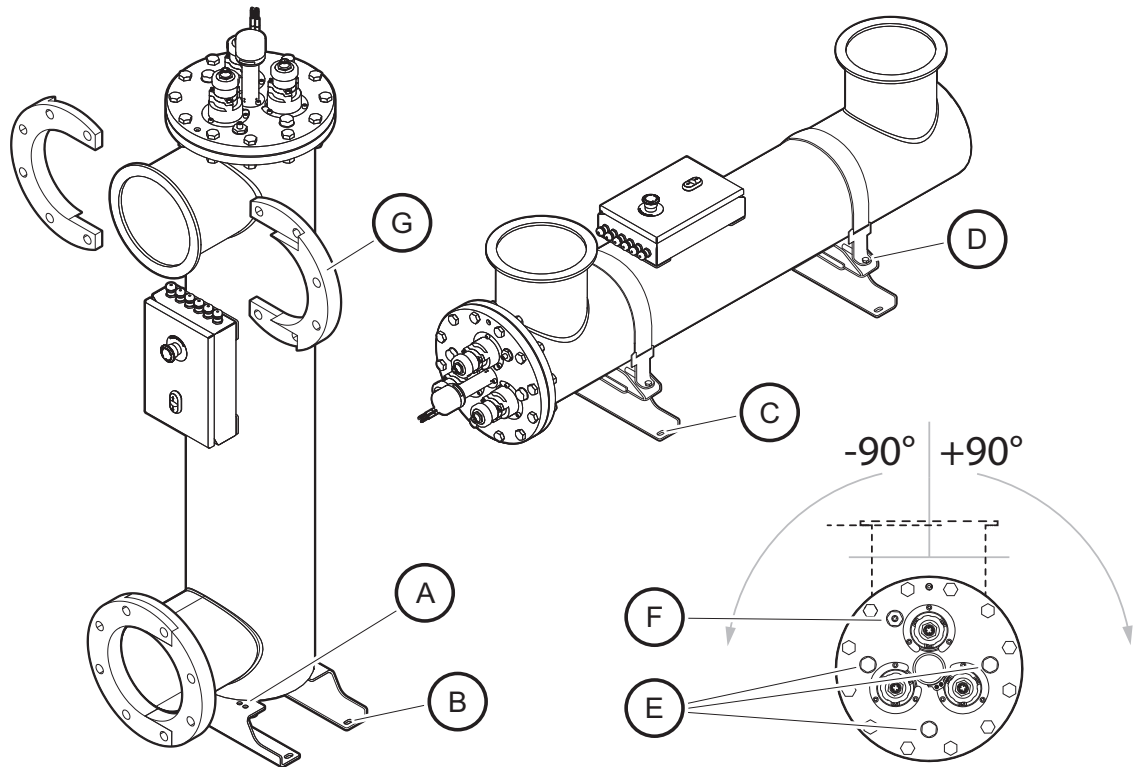

Position	Item
A	Adjustment screws
B	Floor fasteners - Vertical (Not included)
C	Floor fasteners - Horizontal (Not included)
D	Fastening straps (Optional)
E	Aeration plugs
F	Thermo switch
G	Connection flanges



### 5.2.1 Vertical installation (Recommended)

1. Fixate the AquaWorker to the floor stand with appropriate fasteners (B).
2. Level the AquaWorker with the four adjustment screws (A).
3. When the AquaWorker is properly fixated to the ground (and wall), connection to piping network can be done using the connection flanges (G). see "Connecting the flanges" below.

### 5.2.2 Horizontal installation

1. Horizontal installation: Fixate the AquaWorker to the floor with appropriate fasteners (C). Fixation of the AquaWorker to the floor fasteners using straps (D). Position of aeration/drainage plugs (E).
2. The thermo switch (F) must be positioned in the highest possible position. Switch position with highest positioned aeration plug (E) if necessary.
3. When the AquaWorker is properly fixated to the ground (and wall), connection to piping network can be done using the connection flanges (G). See "Connecting the flanges" below

### 5.2.3 Connecting the flanges

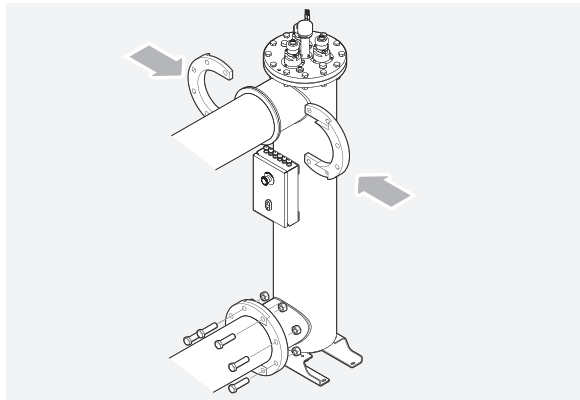

1. Attach the flange connectors (G) using the flange bolts, see Appendix "Tightening torque" on page 65. Use appropriate gasket to seal the connection.

## 5.3 Install UV-lamps

### CAUTION

Do not touch the new lamps with bare hands.  
Use protective gloves!  
Fingerprints may impair the intensity of the light.

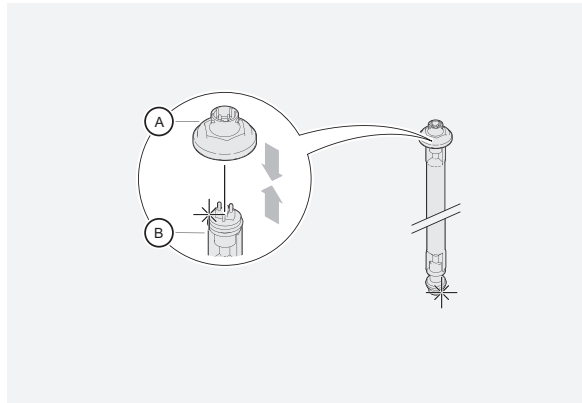

1. Mount the lamp top (A) on to the new lamp (B).

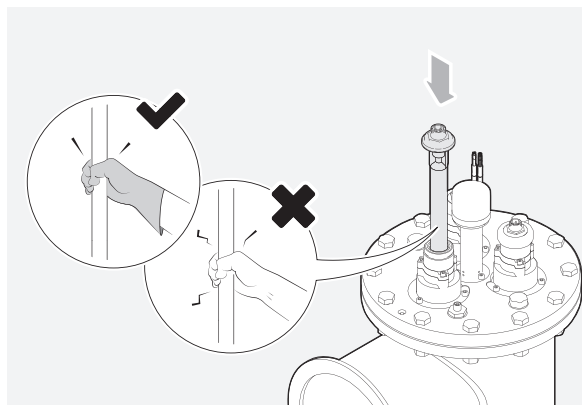

2. Carefully insert the new lamp into the quartz sleeve holder.

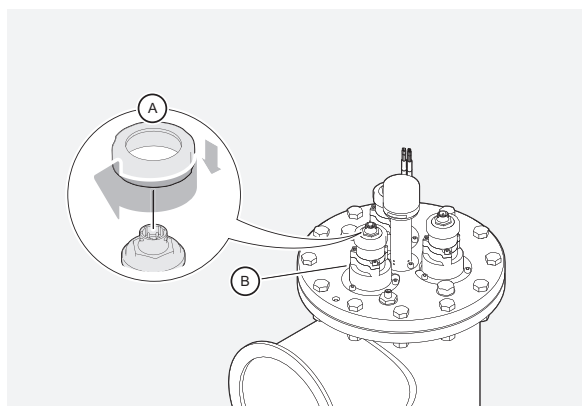

3. Mount the lamp top lock nut (A) on the quartz sleeve holder (B).

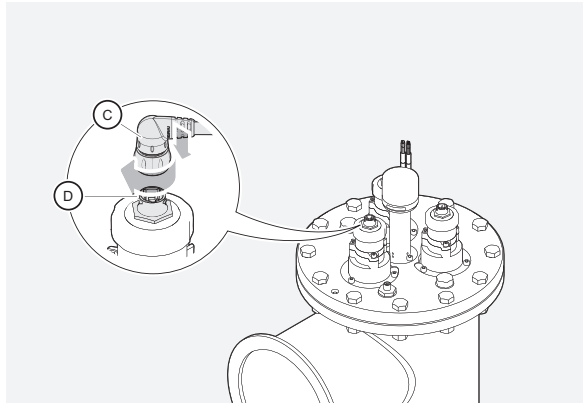

4. Connect the lamp power connector (C) to the lamp top (D).
5. Repeat steps 1 to 4 for the remaining lamps.
6. When all UV-lamps have been installed, the unit is ready for start-up.  
See chapter "Starting up" on page 20.
7. Make a note in Appendix - "Maintenance Record" on page 77 ,  
that all lamps have been installed.

## 5.4 Electrical installation

There are four cables to connect to the AquaWorker junction box.

### 5.4.1 Cables to connect to AquaWorker electrical cabinet

Connect the cables, shown in the electrical drawing "Main Power\_1", to the reactor connection box. See "Electrical drawings" on page 80

Main power 3-phase plug (12) to the source 3P+N+PE (400V/16A, RCD-protected ELCB optional).

### 5.4.2 Cables to connect to AquaWorker reactor junction box

Connect cables, shown in the electrical drawing "Junction box layout", to the reactor junction box. See "Electrical drawings" on page 80

- Cable W7/1 – Lamp cable 1; connect it to Reactor junction box, according to drawing 50-0043 (position D/1).
- Cable W7/2 – Lamp cable 2; connect it to Reactor junction box, according to drawing 50-0043 (position D/2).
- Cable W7/3 – Lamp cable 3; connect it to Reactor junction box, according to drawing 50-0043 (position D/3).
- Cable W9 – Signal cable; connect it to Reactor junction box, according to drawing 50-0043 (position D/5).
- Cable W6 – Anti-corrosion cable; connect it to Reactor junction box, according to drawing 50-0043 (position D/10).

### 5.4.3 Cable routing

The cables between AquaWorker Main electrical cabinet and AquaWorker Junction box must be routed in straight lines. Avoid any roll-up of the cables because this will impair the function. Cut and prepare the cables to fit the specific installation conditions.

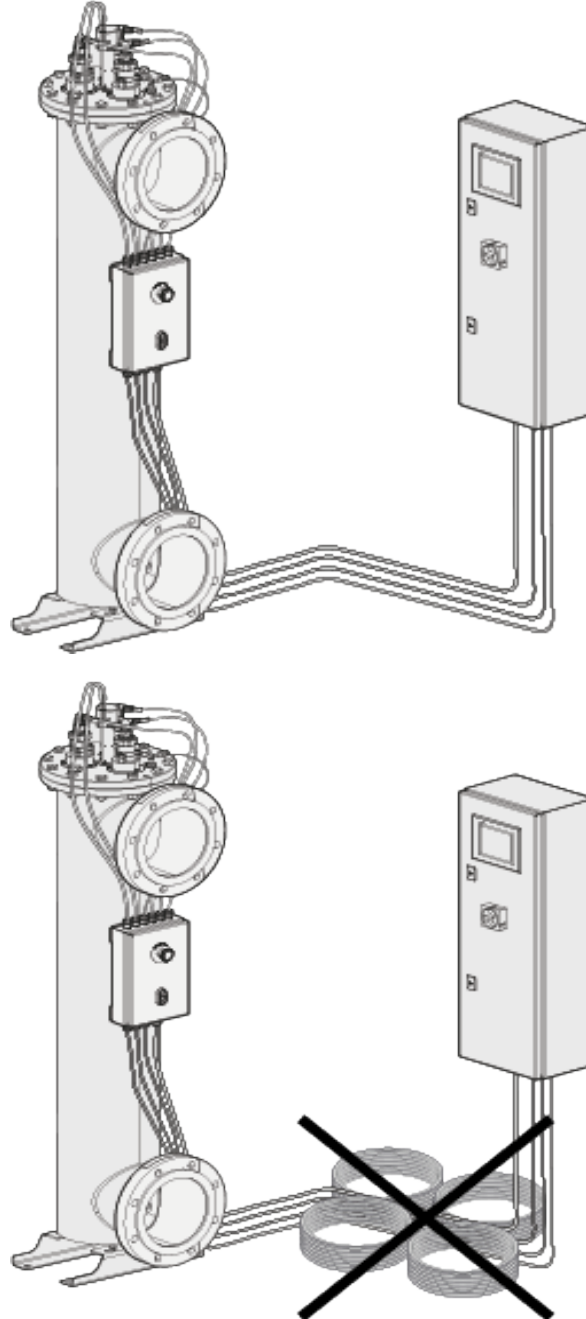

## 6 Operation

### 6.1 Important instructions

#### **WARNING**

**Risk of exposure to UVC rays. UVC rays are harmful to the eyes and the skin, never look into a lit lamp! Always use necessary protective equipment (such as protective glasses and gloves) when working with the quartz sleeves and UV lamps.**

#### **CAUTION**

**Never operate the AquaWorker without water in it!**

#### **CAUTION**

**The water in the AquaWorker must not freeze. Always drain the AquaWorker before storage, transportation or when it is not in use.**

If the AquaWorker or system which it is installed to are left unused for long periods of time (i.e. weeks), cleaning of the entire system might be required.

The lamp power supplies used in AquaWorker are specifically validated to operate with the respective UV lamps provided with the unit. Using non-original components can damage the unit and the surrounding equipment. Any attempt to change or modify existing equipment with non-original components invalidates the warranty.

## 6.2 Starting up

### NOTE

If it is the first time the system is started, see Appendix - "Site acceptance test (SAT)" on page 74 and check step 10-13.

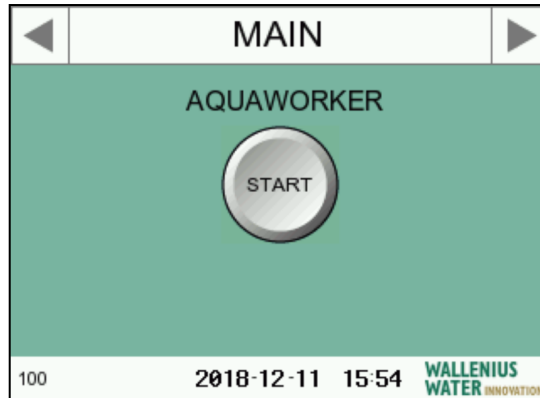

Screen 100 - The start button

1. Confirm that the reactor is filled with water.  
If not, see "Filling and bleeding the AquaWorker" on page 54.
2. Turn the main switch, located on the Electrical Cabinet, to the **ON** position.
3. Press the *START* button on the touch display.  
An automatic cleaning sequence is activated and a progress bar shows the status of the sequence. When the cleaning sequence is finished, the UV lamps ignites. The ignition sequence is shown on a progress bar. The UV-lamps reaches full effect after approximately 5 minutes. If the system does not start, see "Troubleshooting" on page 56.

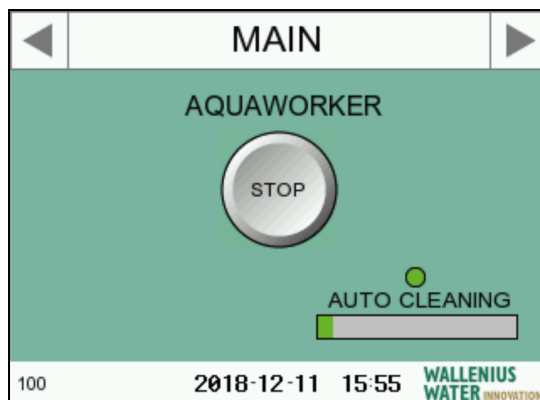

Screen 100 - The automatic cleaning sequence progress

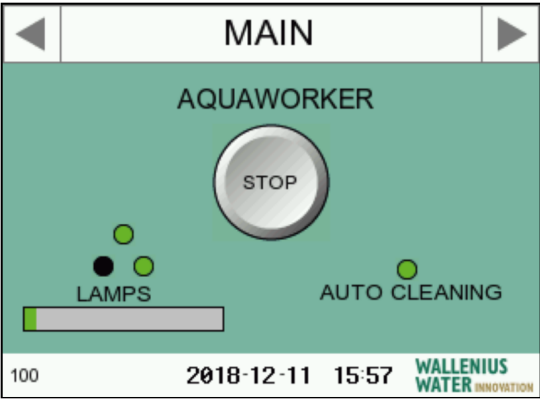

Screen 100 - The UV lamps ignition sequence progress



## 6.3 Turning off

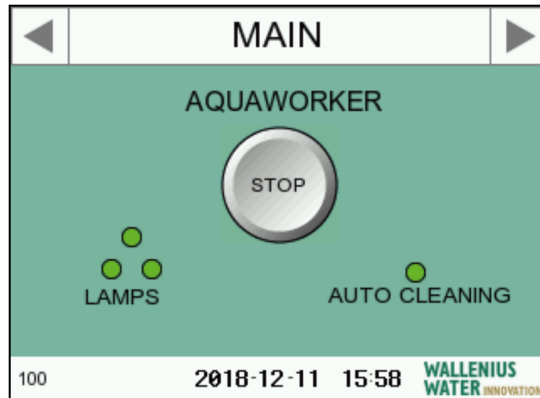

*Screen 100 - The stop button*

1. Press the *STOP* button on the HMI, the system will stop after a few seconds.  
The *STOP* button is on the main page (Screen 100).
2. When the system is stopped, turn off the main switch on the Electrical Cabinet.

## 7 Service and Maintenance

### WARNING

Risk of exposure to UVC rays. UVC rays are harmful to the eyes and the skin, never look into a burning lamp! Always use necessary protective equipment (such as protective glasses and gloves) when working with the quartz sleeves and the UV lamps.

### WARNING

The unit operates with electrical power. Electrical power can cause electrical chocks. Disconnect power before service and use a residual current device, RCD.

### CAUTION

Do not touch the quartz sleeve with bare hands. Use protective gloves! Fingerprints may impair the intensity of the light.

### NOTE

Wallenius Water Innovation AB only guarantees correct function of the unit with original or specified components.

The AquaWorker utilizes ultraviolet lamps encased in quartz sleeves to separate the fluid from direct contact with the lamp itself. The quartz sleeves can get contaminated with scaling depending on the concentration of salts and minerals in your water.

## 7.1 Quartz sleeve cleaning

The quartz sleeves require regular cleaning since iron, calcium and magnesium (which are always present in the water in varying concentrations) form a brownish scaling on the outside of the sleeves. If the quartz sleeves are not cleaned, the scaling will reduce the UV irradiation of the water and impair the function of the reactor.

See Appendix - "Maintenance Record" on page 77.

### NOTE

Clean only one quartz sleeve at a time.

### NOTE

Manual operation ("Service") of the wiper can be controlled through the HMI or directly on the terminal box of the reactor.

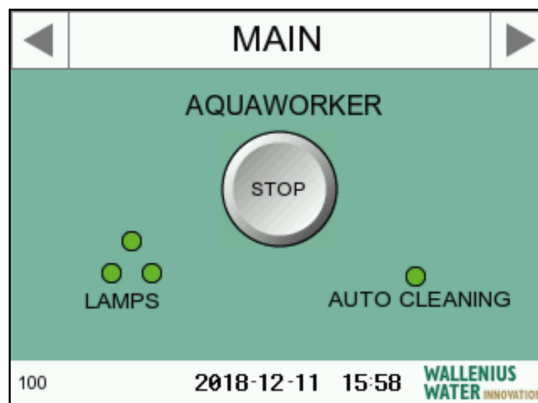

1.

On the MAIN screen, press *STOP* to stop the system. The system stops a few seconds after the button has been pressed.

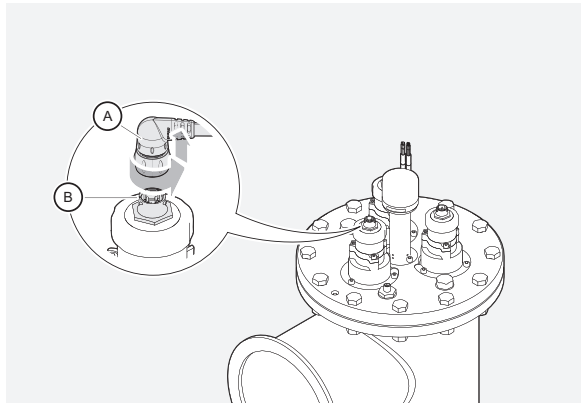

2.

Remove the lamp power connector (A) from the lamp top (B).

3.

Close the inlet and outlet valves to the AquaWorker.

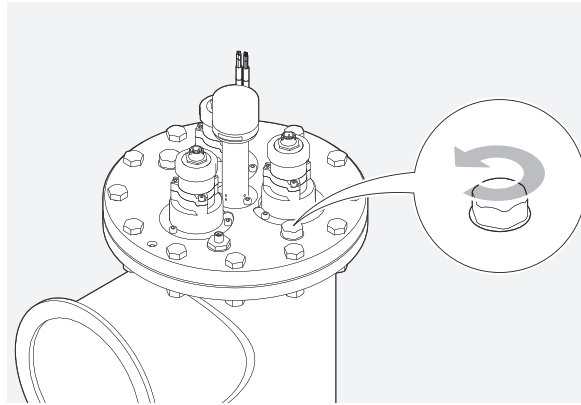

4.

Pressure relief the AquaWorker by opening one of the aeration plugs.

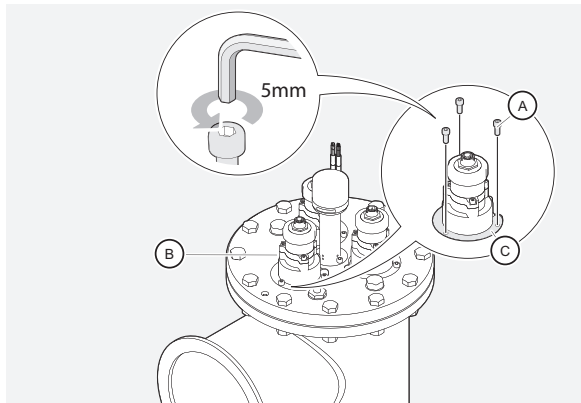

5.

Remove the three screws (A) to remove the quartz sleeve holder (B) from the reactor. Place the three screws (A) together with the pressure plate (C), in a temporary safe place.

**CAUTION**

**Do not touch the quartz sleeve with bare hands.  
Use protective gloves!**

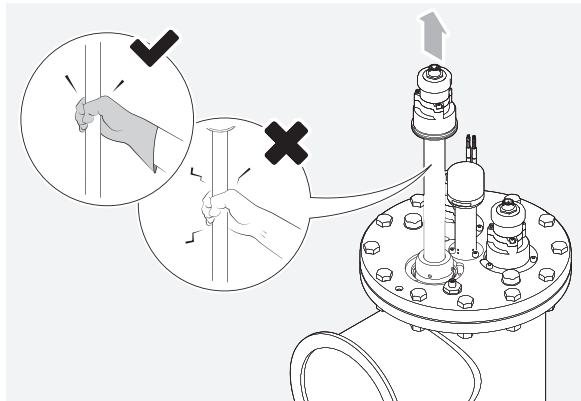

6.

Gently lift the quartz sleeve and holder assembly from the reactor straight up until the full length of the quartz sleeve is outside the reactor.

**CAUTION**

**Ensure that no cleaning solution drips onto the unit.  
Hold the quartz sleeve on the side of the unit.**

**CAUTION**

**Do not apply acid on the reactor, socket or lamp top.**

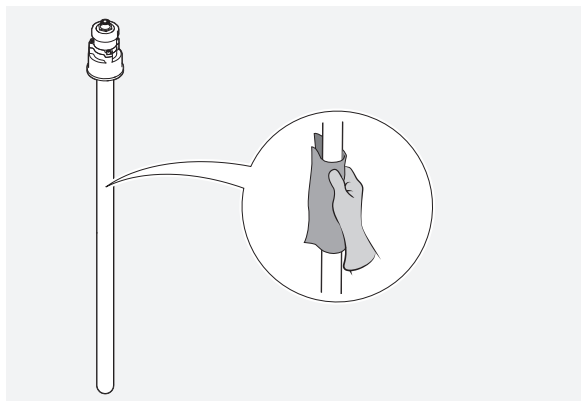

7.

Apply a weak acid solution (e.g. citric acid) onto a cloth and carefully wipe the quartz sleeve clean making sure that no cleaning solution drips onto the unit.

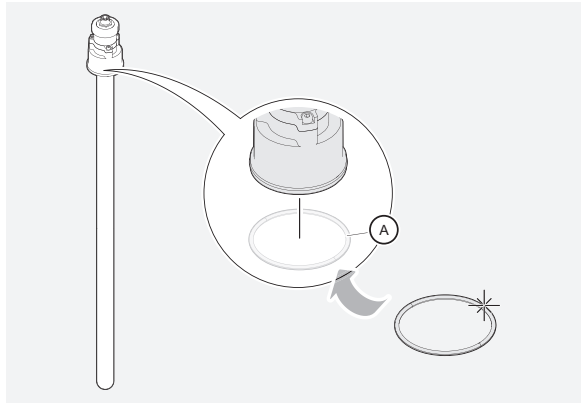

8.

Check the o-ring (A) at the bottom of the quartz sleeve holder for damages and replace it if necessary. See "Before installation" on page 10.

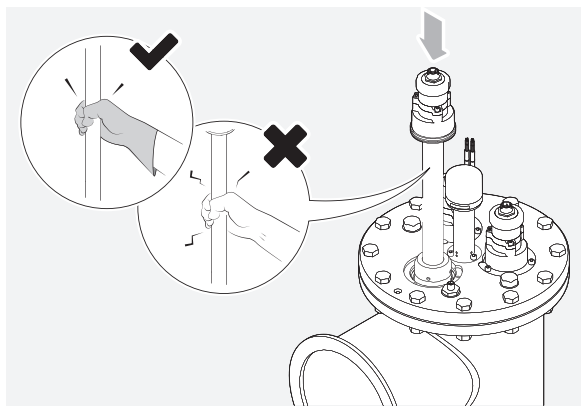

9.

Gently insert the cleaned quartz sleeve and holder assembly into the reactor. Insert the last bit of the quartz sleeve very slowly and gently to ensure that it enters the bottom holder correctly.

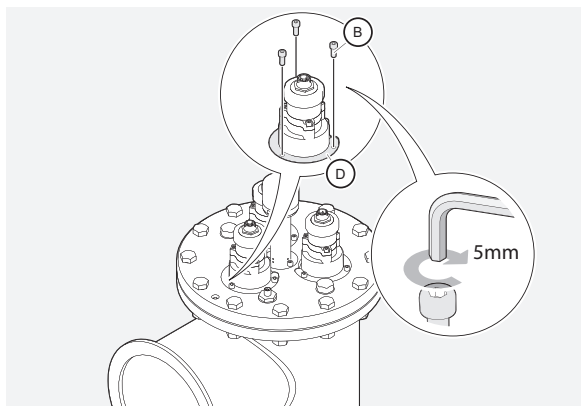

10.

Use the three screws (B) to fasten and tighten the pressure plate (D). See "Tightening torque" on page 65.

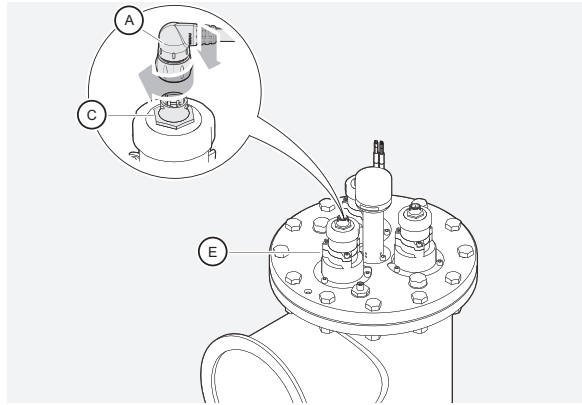

11. Mount the lamp power connector (A) on to the lamp top (C).
12. Wipe away any water around the quartz sleeve holder (E) with a cloth.
13. Repeat steps 6-13 on the remaining quartz sleeves.

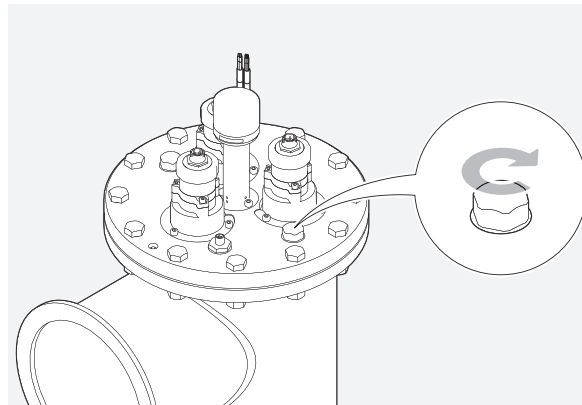

14. Make sure all unscrewed parts are properly fastened, including the aeration plug. See "Tightening torque" on page 65.
15. Open the inlet and outlet valves to the AquaWorker.
16. The unit is ready for start-up.  
See chapter "Starting up" on page 20.
17. Reset the clean interval timer on the maintenance screen. See "Screen 130 – Maintenance" on page 69
18. Make a note in the "Maintenance Record" on page 77 that the quartz sleeves have been cleaned.

## 7.2 Lamp replacement

### WARNING

Wait approximately 10 minutes after the power is shut down before working on the AquaWorker in order to let it cool off.

### 7.2.1 Interval

For recommended service intervals, see "Spare parts list" on page 59

### 7.2.2 Tools and materials

Description	Note
Protective gloves	Use clean protective gloves

### 7.2.3 Procedure

### CAUTION

Do not use tools when replacing the lamps. The lamps are very sensitive to any form of contamination. Always use clean protective gloves when touching the lamps.

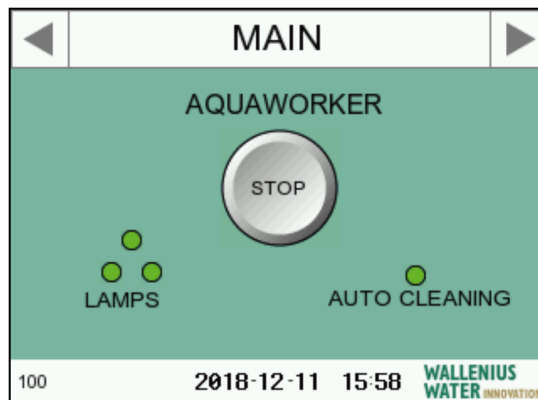

1.

On the HMI on the electrical cabinet, press the "STOP" button to shut down the AquaWorker.



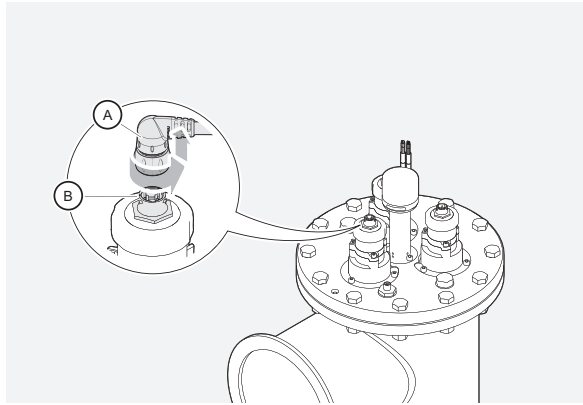

2.

Remove the lamp power connector (A) from the lamp top (B).

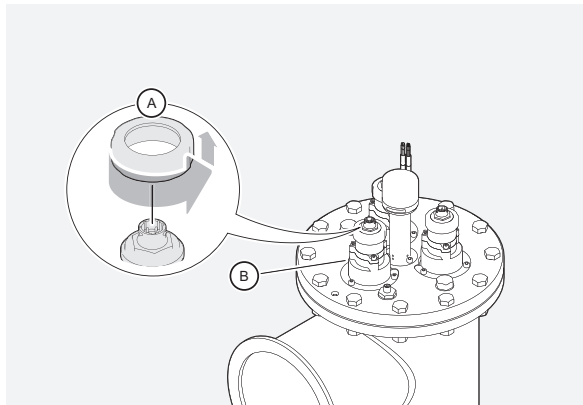

3.

Remove the lamp top lock nut (A) from the quartz sleeve holder (B).

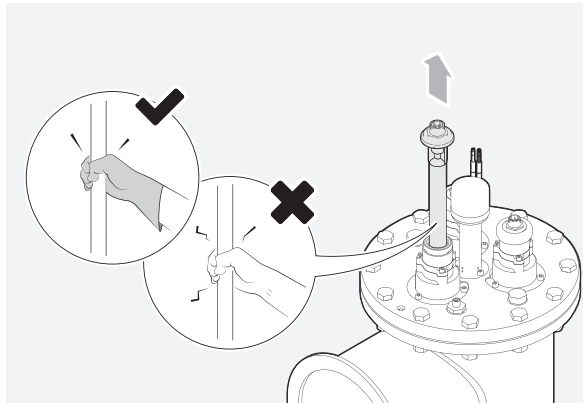

4.

Use the lamp top to carefully pull out the lamp from the holder.

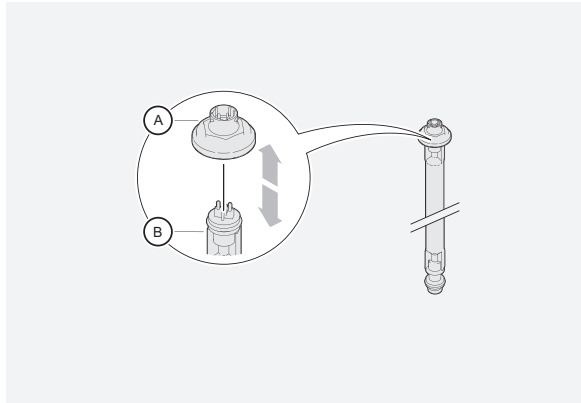

5. Separate the lamp (B) from the lamp top (A) by pulling them apart.

**CAUTION**

**Do not touch the new lamps with bare hands.  
Use protective gloves!  
Fingerprints may impair the intensity of the light.**

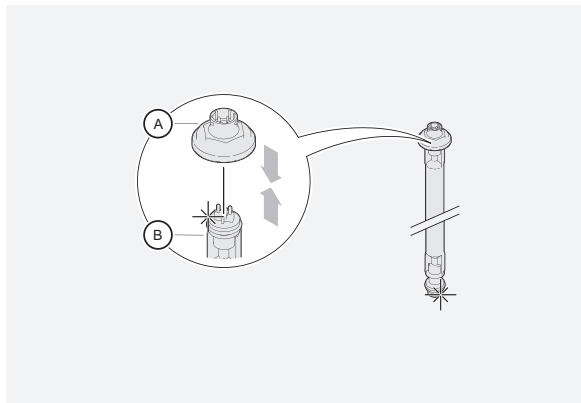

6. Mount the lamp top (A) on to the new lamp (B).

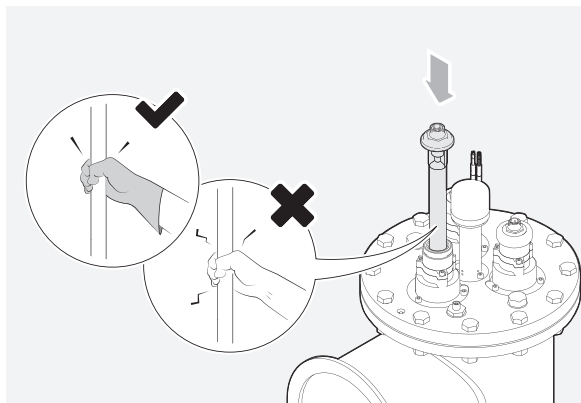

7. Carefully insert the new lamp into the quartz sleeve holder.

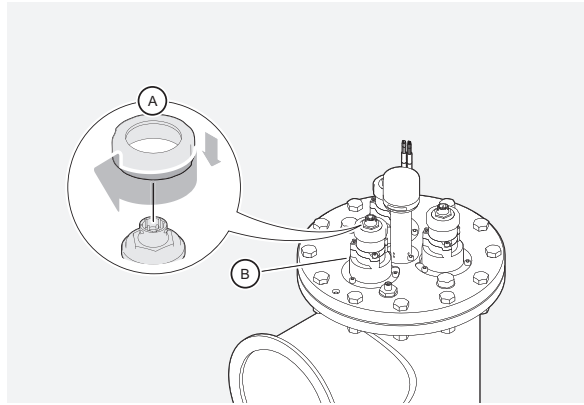

8. Mount the lamp top lock nut (A) on the quartz sleeve holder (B).

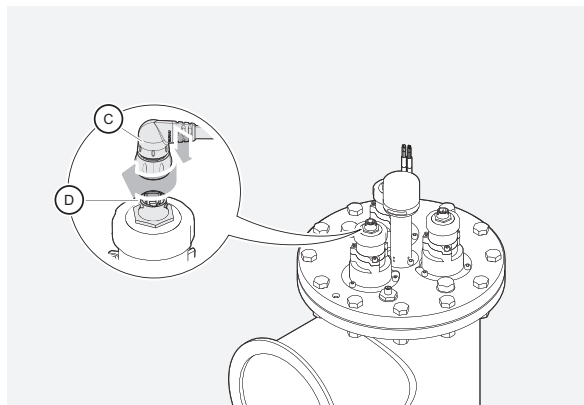

9. Connect the lamp power connector (A) to the lamp top (B).
10. Repeat steps 2 to 9 for the remaining lamps.
11. When all UV lamps have been replaced, the unit is ready for start-up. See chapter "Starting up" on page 20.
12. Make a note in the "Maintenance Record" on page 77, that the all lamps have been replaced.

## 7.3 Cleaning system service

### 7.3.1 Interval

The cleaning system service interval depends on the quality and the properties of the water and must be established individually for each installation.

### 7.3.2 Tools and materials

Description	Note
Protective gloves	Use clean protective gloves
Wrench	27 mm
Allen key	5 mm

### 7.3.3 Procedure

#### NOTE

Replace one cleaning cartridge at a time. Make sure the quartz sleeves are clean before replacing with new cartridges. Refer to procedure in chapter 7.1.

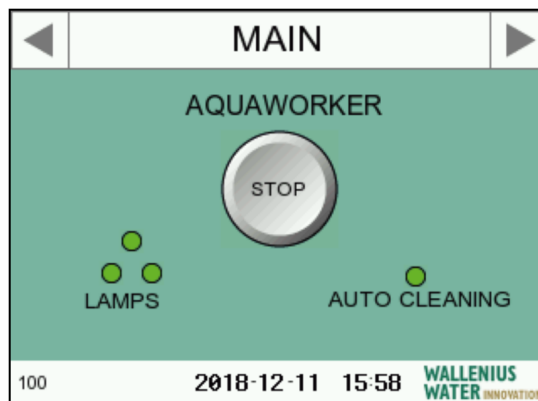

1. On the MAIN screen, press *STOP* to stop the system. The system stops a few seconds after the button has been pressed.
2. Close the inlet and outlet valves to the AquaWorker.

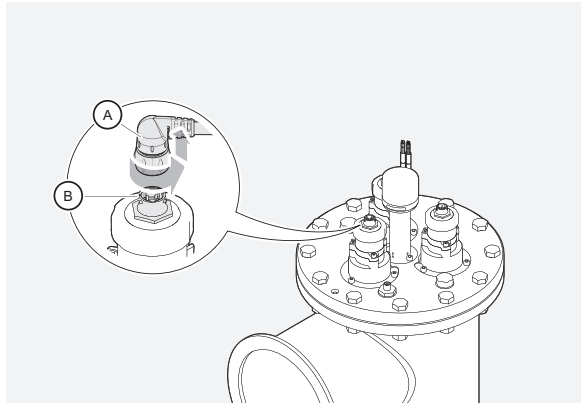

3. Remove the lamp power connector (A) from the lamp top (B).

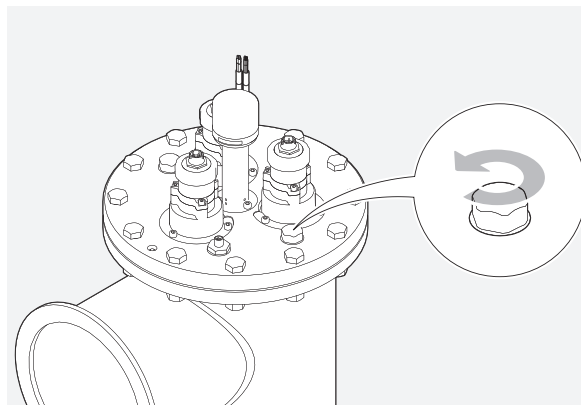

4. Open one of the aeration plugs to relieve the pressure from the AquaWorker.

5. Remove the first quartz sleeve, see "Quartz sleeve cleaning" on page 24, steps 5-7.

6. Place the quartz sleeve where it is protected

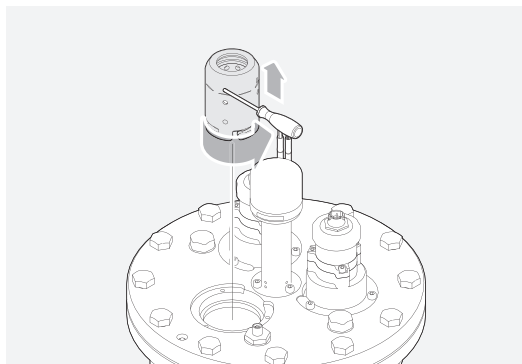

7. The cleaning system cartridge is now reachable for removal. Grip the cartridge by hand and twist the cartridge counter-clockwise (Optional: Removal of the cartridge can be simplified with the use of a screwdriver inserted into one of the upper holes of the cartridge).

The cartridge is now released from the holder and can be removed.

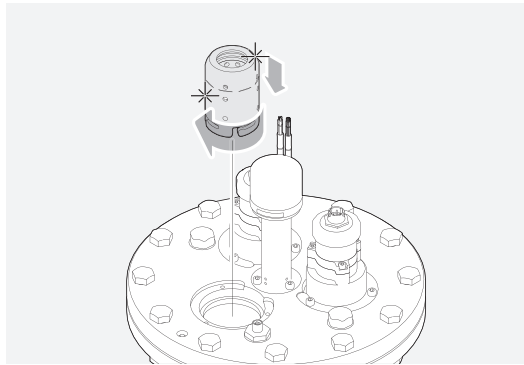

8. Mount a new cartridge. Push the cartridge gently downwards and twist the cartridge clockwise. Make sure the cartridge is securely fastened.
9. Re-mount the first quartz sleeve, see chapter "Quartz sleeve cleaning" on page 24, steps 10-11.
10. Repeat steps 5-11 for the remaining cartridges.
11. Make sure all unscrewed parts are properly refastened, including the aeration plug.
12. Open the inlet and outlet valves to the AquaWorker.
13. When all cleaning cartridges have been replaced, the unit is ready for start-up. See chapter "Starting up" on page 20.
14. Reset the clean interval timer on the maintenance screen. For more information go to chapter "Screen 130 – Maintenance" on page 69.
15. Make a note in the "Maintenance Record" on page 77, that the cleaning cartridges have been cleaned.
16. Recycle parts according to chapter "Disposal" on page 2.

## 7.4 Quartz sleeve replacement

### WARNING

Wait approximately 10 minutes after the power is shut down before working on the AquaWorker in order to let it cool off.

### 7.4.1 Interval

Quartz sleeves are replaced when necessary.  
See "Spare parts list" on page 59

### 7.4.2 Tools and materials

Description	Note
Protective gloves	Use clean protective gloves
Allen key	5 mm
Sealing kit, lamp top	Replacement o-rings for the quartz sleeve holder

### 7.4.3 Procedure

#### CAUTION

Do not use tools when replacing the sleeves. The lamps are very sensitive to any form of contamination. Always use clean protective gloves when touching the sleeves.

#### NOTE

Replace one quartz sleeve and lamp at a time

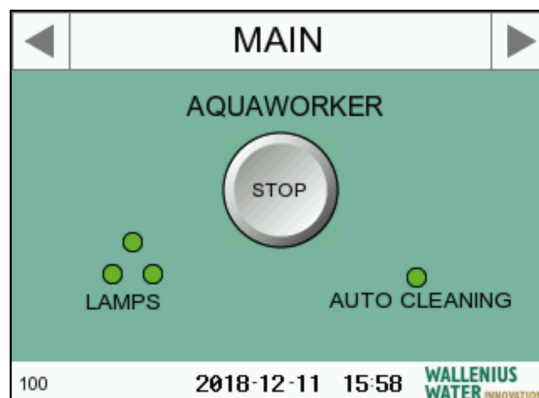

1. On the MAIN screen, press *STOP* to stop the system. The system stops a few seconds after the button has been pressed.

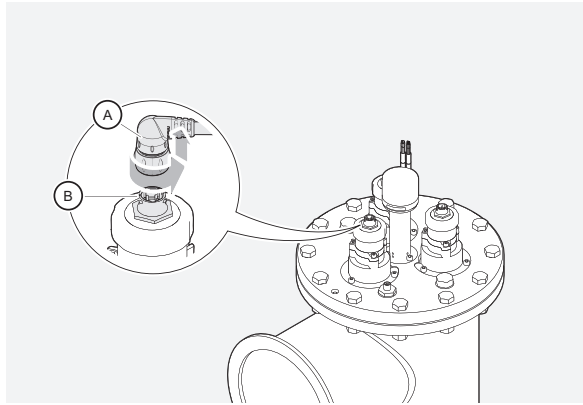

2.

Remove the lamp power connector (A) from the lamp top (B).

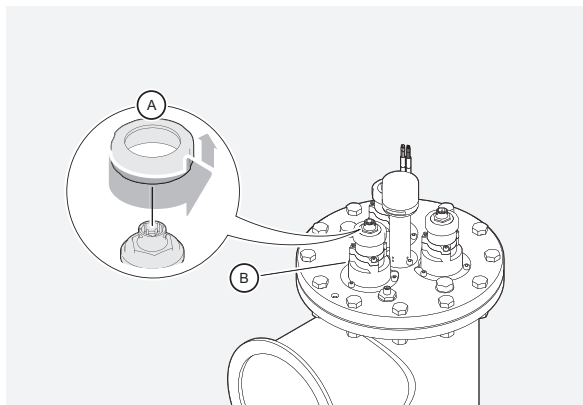

3.

Remove the lamp top lock nut (A) from the quartz sleeve holder (B).



**CAUTION**

Take care not to touch the lamp with bare hands. Always use clean protective gloves when touching the lamps.

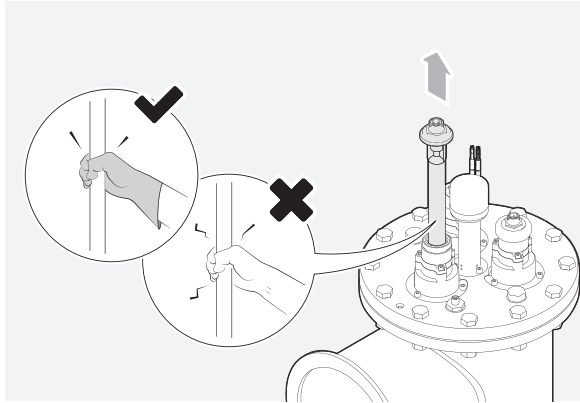

4. Use the lamp top to carefully pull out the lamp from the quartz sleeve holder.

5. Place the lamp where it is protected.

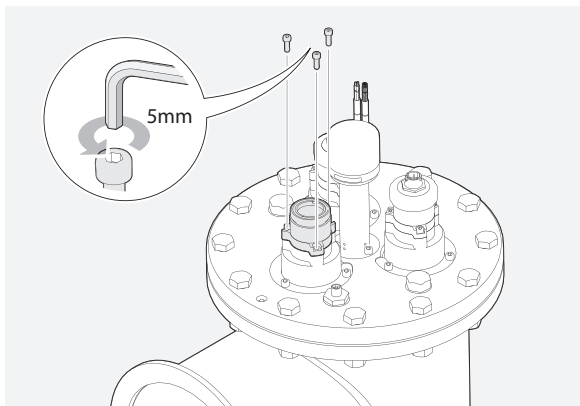

6. Use Allen-key to remove the three screws (A) to remove the upper holder from the lower quartz sleeve holder. Put the screws in a safe place.

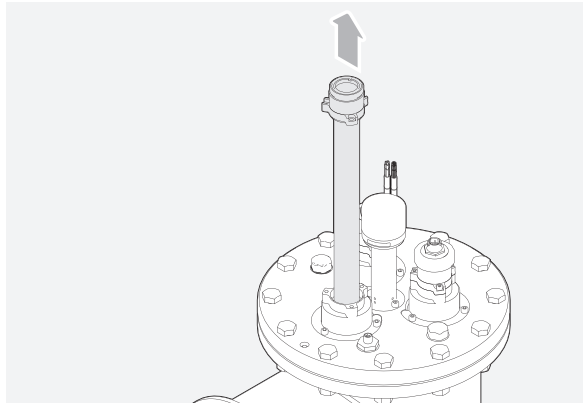

7.

Holding the upper quartz sleeve holder with your hand, gently pull it out from the lower quartz sleeve holder (and reactor) in a straight manner until the full length of the quartz sleeve is outside the reactor.

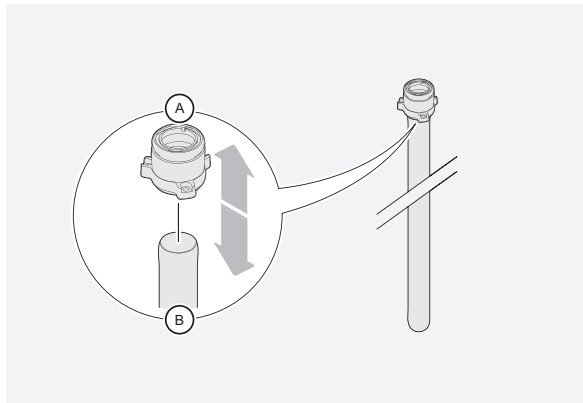

8.

Separate the quartz sleeve (B) from the upper holder (A) by pulling them apart.

9. Replace the upper sleeve holder O-rings.

Mount the O-rings on the quartz sleeve and lubricate with clean water to facilitate the next step.

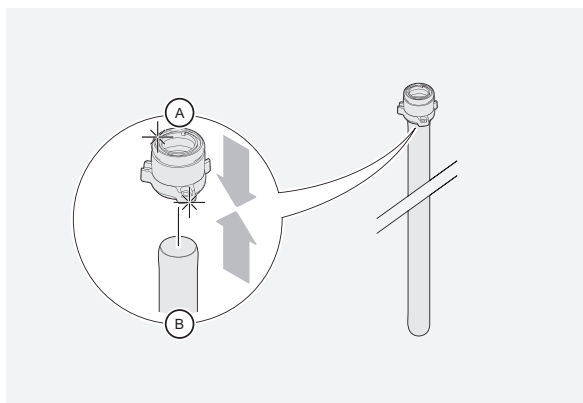

10.

Push the new quartz sleeve (B) in to the upper holder (A).

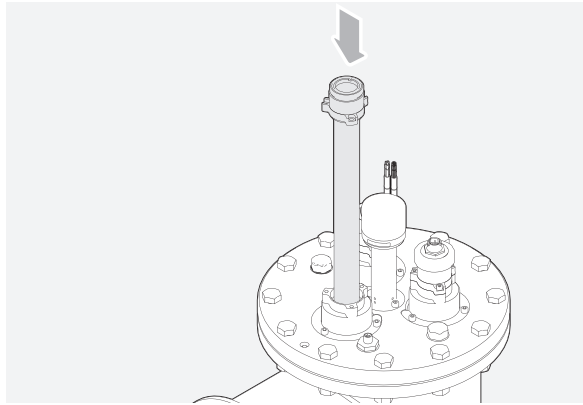

11.

Gently push the new quartz sleeve into the reactor and the lower quartz sleeve holder in a straight manner until the full length of the quartz sleeve is inside the reactor.

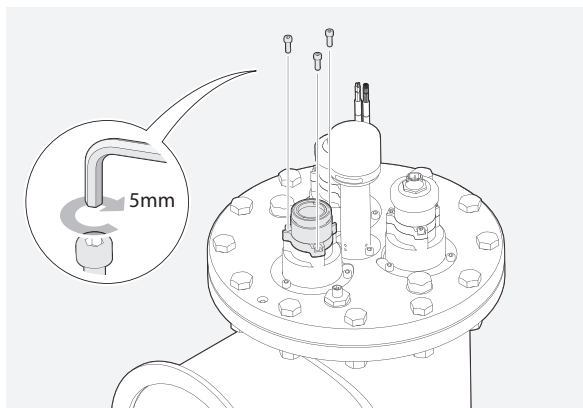

12.

Mount and tighten the upper holder to the lower quartz sleeve holder using an Allen-key for the three screws. See chapter "Tightening torque" on page 65.

13. Repeat steps 3-12 for the remaining quartz sleeves.
14. Open the inlet and outlet valves to the AquaWorker.
15. When all quartz sleeves have been replaced, the unit is ready for start-up. See chapter "Starting up" on page 20.
16. Make a note in the "Maintenance Record" on page 77 that the quartz sleeves have been replaced.
17. Recycle parts according to chapter "Disposal" on page 2.

## 7.5 Bearing and sealing service

### WARNING

Wait approximately 10 minutes after the power is shut down before working on the AquaWorker in order to let it cool off.

### 7.5.1 Interval

For recommended service intervals, see "Spare parts list" on page 59

### 7.5.2 Tools and materials

Description	Note
Protective gloves	Use clean protective gloves
Pressing tool	For assembly/disassembly of bearings
Allen key	2,5 mm
Allen key	5 mm
Wrench	27 mm
Silicone grease	Molycote 111 or similar

### 7.5.3 Procedure

#### NOTE

The following instruction applies to both the upper and lower bearing attachments.

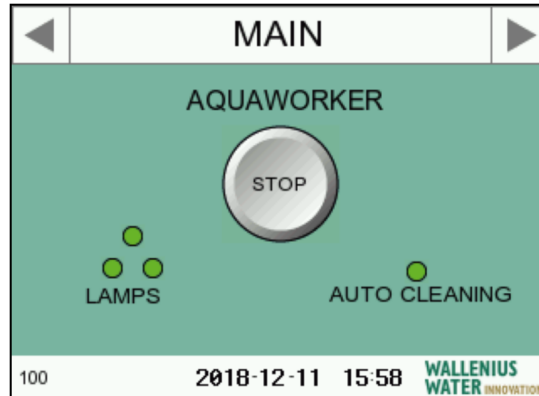

1. On the MAIN screen, press *STOP* to stop the system. The system stops a few seconds after the button has been pressed.
2. Drain the AquaWorker, see "Draining the AquaWorker" on page 53

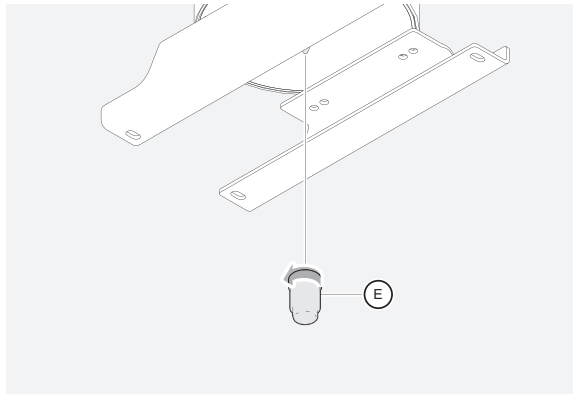

3. Lower bearing: Unscrew the lower bearing housing (E) completely using the wrench.
4. Remove the inner housing (B) from the bearing housing (E).
5. Replace the O-rings and bearing with new ones. Assembly of the bearing is facilitated by a pressing tool.

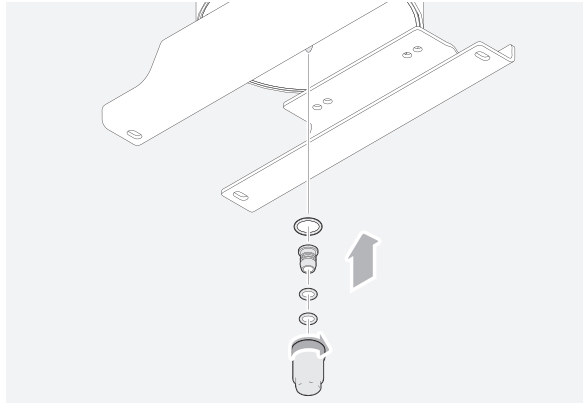

6.

Re-mount the lower bearing assembly into the reactor.

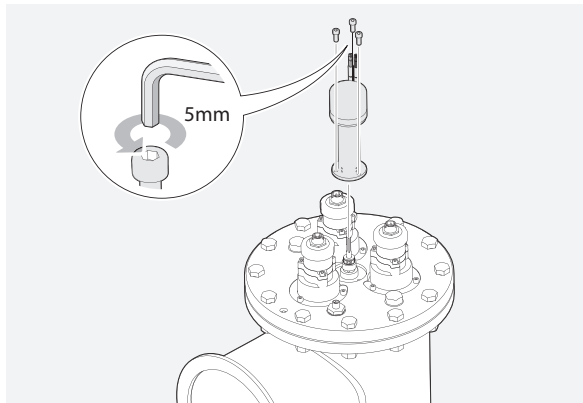

7.

Upper bearing: Unscrew the three screws to loosen the motor and its stand from the reactor. This will enable accessibility of the upper bearing housing. Place the motor and attachments where it is protected.

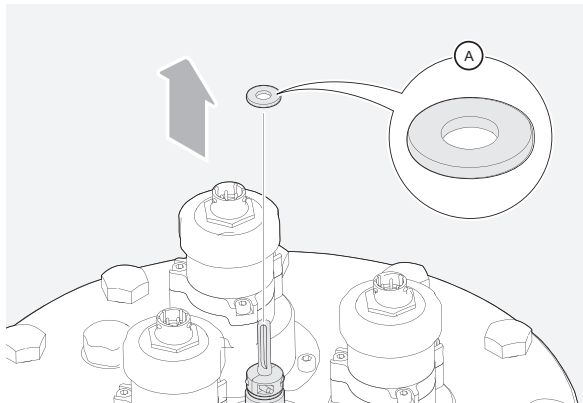

8.

Remove the upper washer (A). Place it where it is protected.

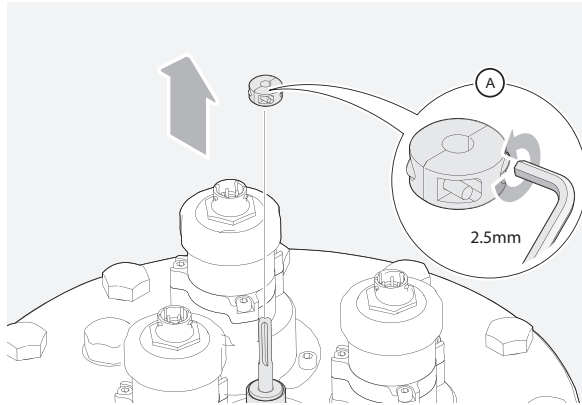

9. Unscrew and remove the Shaft collar (A) using an Allen key. Place it where it is protected.

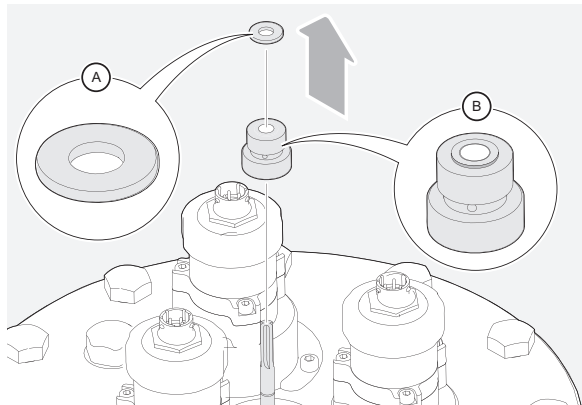

10. Remove the lower washer (A). Place it where it is protected. Now it's possible to release the upper bearing housing (B) from the lead-screw by hand.

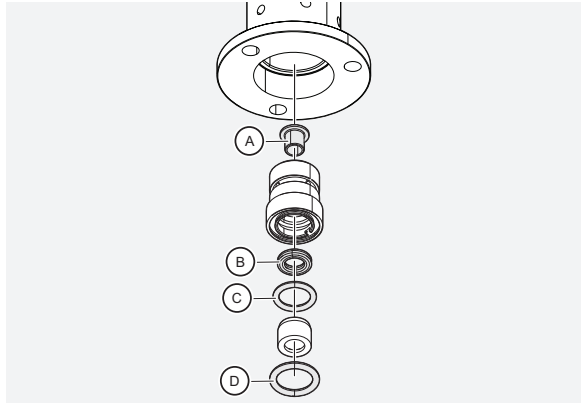

11.

Remove and replace the plain bearing (A), X-ring (B), O-ring (C), and O-ring (D) with new parts. Grease the X-ring amply with Molycote 111 or similar silicone grease. Correct position of the x-ring (B) is ensured when the sealing plugs (1) top face is flush with the bearing sealing housings face. Use only non-sharp tools to put the rings in place. Mounting of the flange bearing is facilitated using a pressing tool.

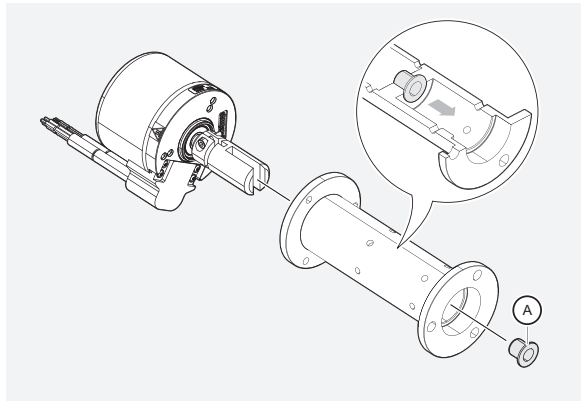

12.

Remove and replace the plain bearing (A). Assembly of the bearing might require a pressing tool.

13. Install the upper bearing by following step 7 to 12 above in opposite order. Take care when re-mounting the screws for the motor and its stand into the reactor. Use of thread lubricant is required.
14. Make a note in the "Maintenance Record" on page 77 that the bearings have been changed.
15. Fill and bleed the AquaWorker, see "Filling and bleeding the AquaWorker" on page 54.



## 7.6 Replacing lead screw nut

Opening the reactor give access to components in the reactor, such as the lead screw nut and other parts in need of replacement.

Moreover, accessibility to the inside of the reactor could be useful also in the event of manual cleaning.

### 7.6.1 Interval

The lead screw nut should be replaced according to the service interval in the "Spare parts list" on page 59

### 7.6.2 Tools and materials

Description	Note
Protective gloves	Use clean protective gloves
Allen key	2.5 mm
Allen key	4 mm
Allen key	5 mm
Wrench	24 mm
Wrench	27 mm

### 7.6.3 Procedure

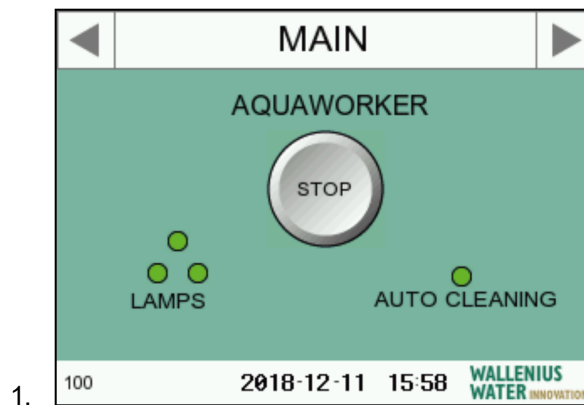

On the MAIN screen, press *STOP* to stop the system. The system stops a few seconds after the button has been pressed.

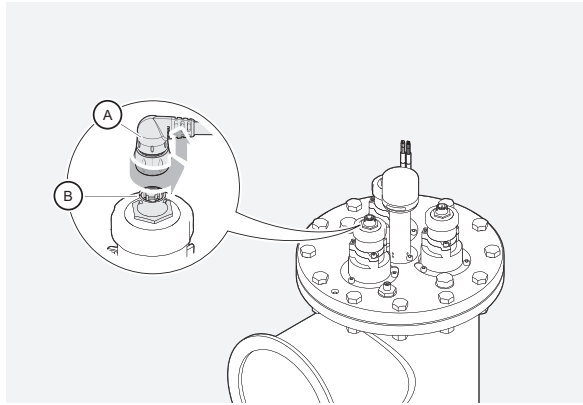

2. Remove the lamp power connector (A) from the lamp top (B).

3. Close the inlet and outlet valves to the AquaWorker.

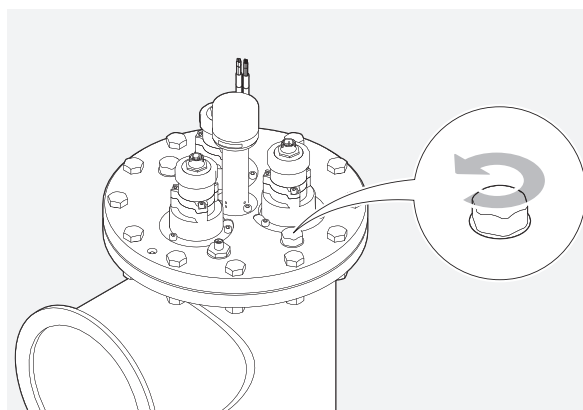

4. Pressure relief the AquaWorker by opening one of the aeration plugs.

5. Drain the AquaWorker, see "Draining the AquaWorker" on page 53

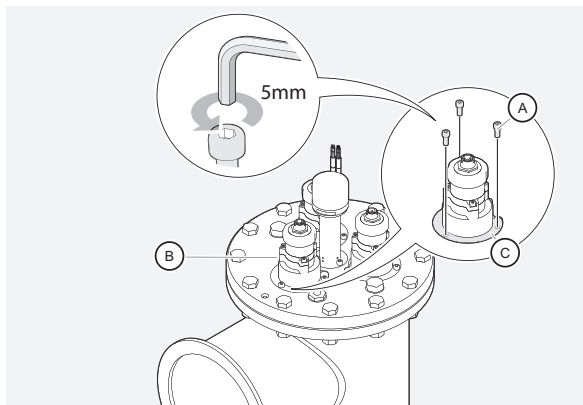

6. Remove the three screws (A) to remove the quartz sleeve holder (B) from the reactor. Place the three screws (A) together with the pressure plate (C), in a temporary safe place.

**CAUTION**

**Do not touch the quartz sleeve with bare hands.  
Use protective gloves!**

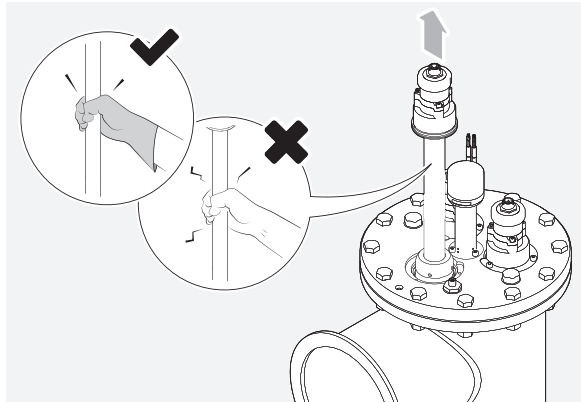

7.

Gently lift the quartz sleeve and holder assembly from the reactor straight up until the full length of the quartz sleeve is outside the reactor.

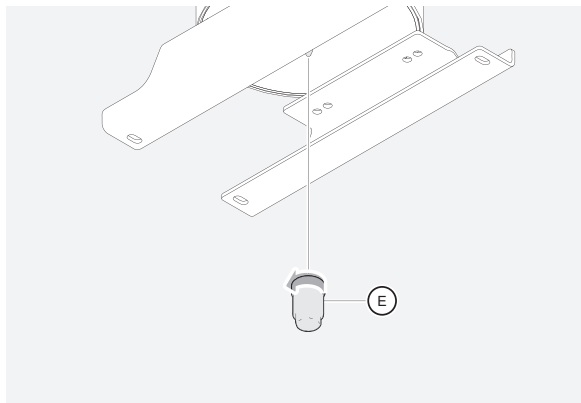

8.

Lower bearing: Unscrew the lower bearing housing (E) completely using the wrench.

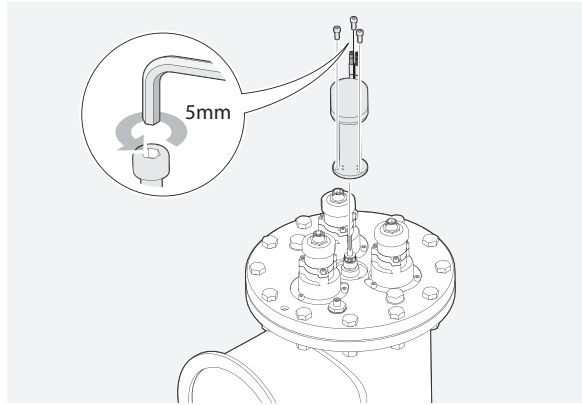

9.

Upper bearing: Unscrew the three screws to loosen the motor and its stand from the reactor. This will enable accessibility of the upper bearing housing. Place the motor and attachments where it is protected.

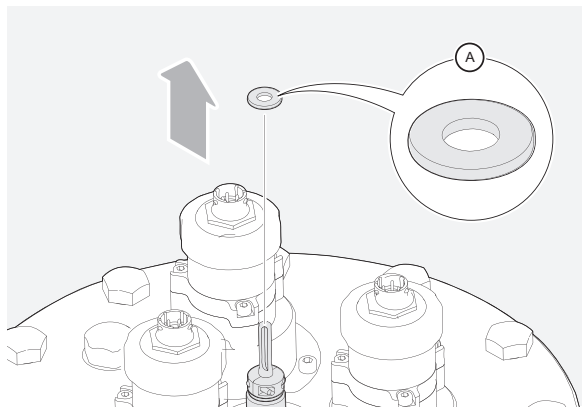

10.

Remove the upper washer (A). Place it where it is protected.

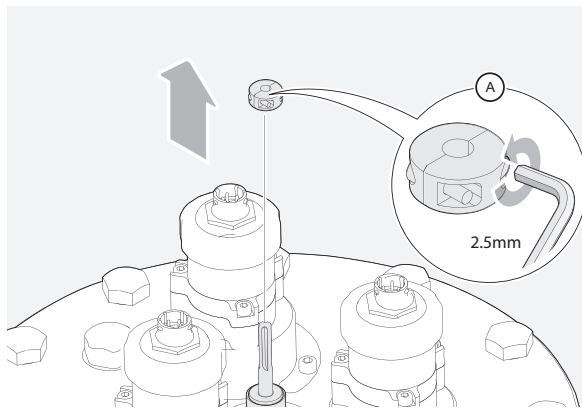

11.

Unscrew and remove the Shaft collar (A) using an Allen key. Place it where it is protected.

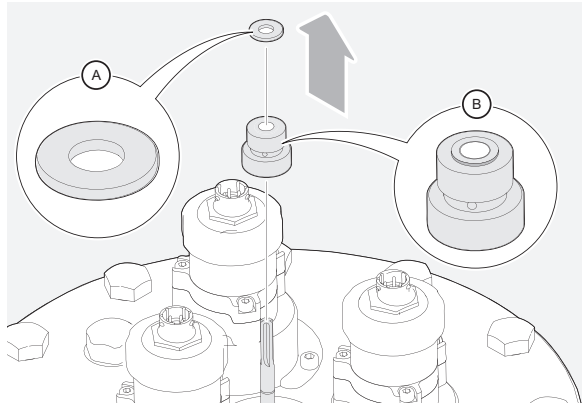

12. Remove the lower washer (A). Place it where it is protected. Now it's possible to release the upper bearing housing (B) from the lead-screw by hand.
13. Remove the thermo switch cable.
14. Loosen and remove all top plate bolts.

**CAUTION**

**Remove the top plate carefully to avoid damage to any parts.**

15. Remove the top plate from the reactor. Place it where it is protected.

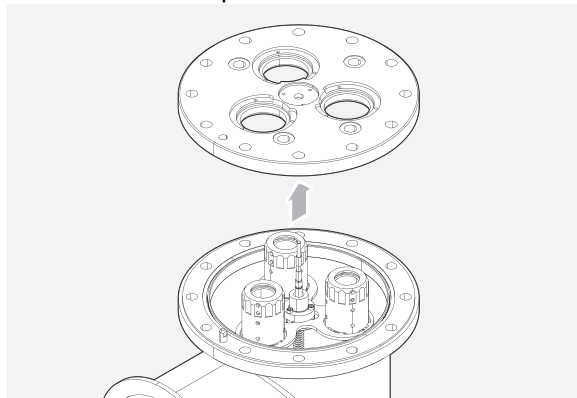

16. Unscrew the wiper assembly from the lead screw.

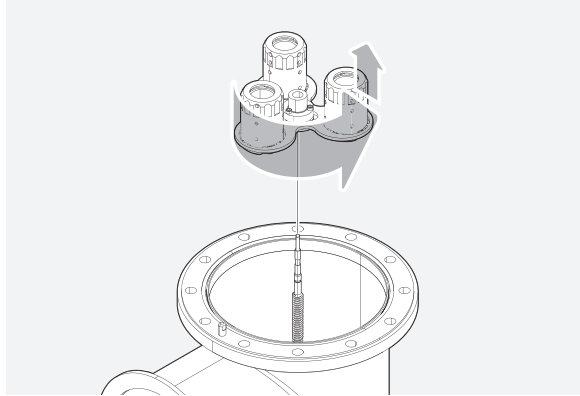

17. Loosen and remove the screws (4) holding the lead screw nut (3).
18. Remove the old lead screw nut (3).
19. Mount a new lead screw nut.
20. Lubricate the screws (4).
21. Tighten the screws (4). Tighten to 2.5 - 3 Nm.
22. Remount the wiper assembly on to the lead screw.
23. Screw the wiper assembly into the reactor until the distance between the top of the cartridges and the reactor top surface is at least 50 mm.

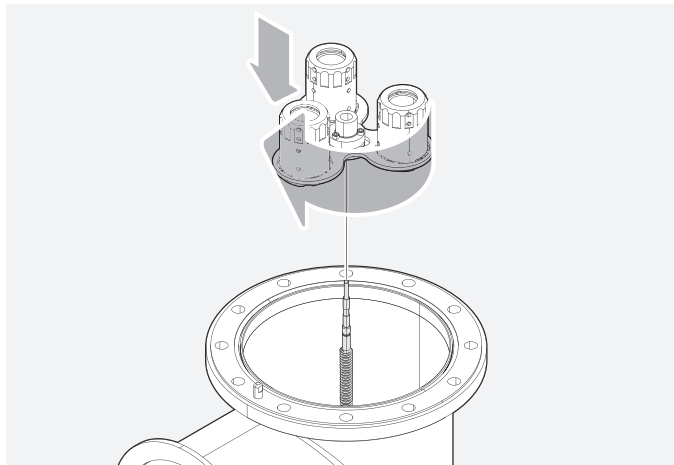

24. Remount the top plate onto the reactor.  
Use the positioning pin to ensure correct position of the top plate.

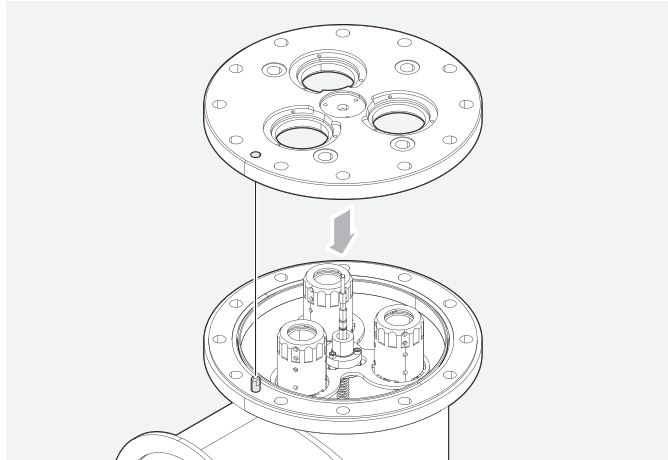

25. Remount all other parts by following steps 2 - 13 in reverse order.
26. Mount the top plate. See "Tightening torque" on page 65.
27. Make a note in the "Maintenance Record" on page 77 that the lead screw nut has been replaced.
28. Recycle parts according to chapter "Disposal" on page 2

## 7.7 Draining the AquaWorker

### 7.7.1 Procedure

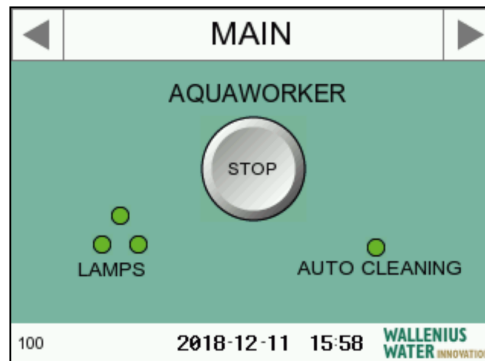

1. On the HMI on the electrical cabinet, press the “STOP” button to shut down the AquaWorker.
2. Close the inlet and outlet valves to the AquaWorker.

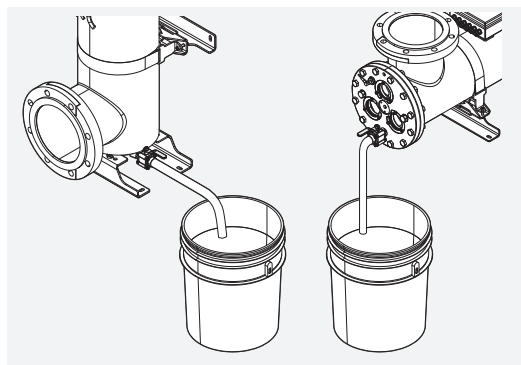

3. Drain the AquaWorker completely by following these steps:
  - a. Place a drain pan under the drainage port or use other equipment to collect the drained water. The reactor contains approx. 80 liters of water.
  - b. Unscrew the drainage port completely (depending on installation, use the lowest positioned port). Continue until all the liquid is drained. Loosen the aeration port for faster drainage.
4. Close the drainage port.



## 7.8 Filling and bleeding the AquaWorker

1. Make sure that the AquaWorker is properly connected to the piping system. See "Connecting the AquaWorker" on page 13

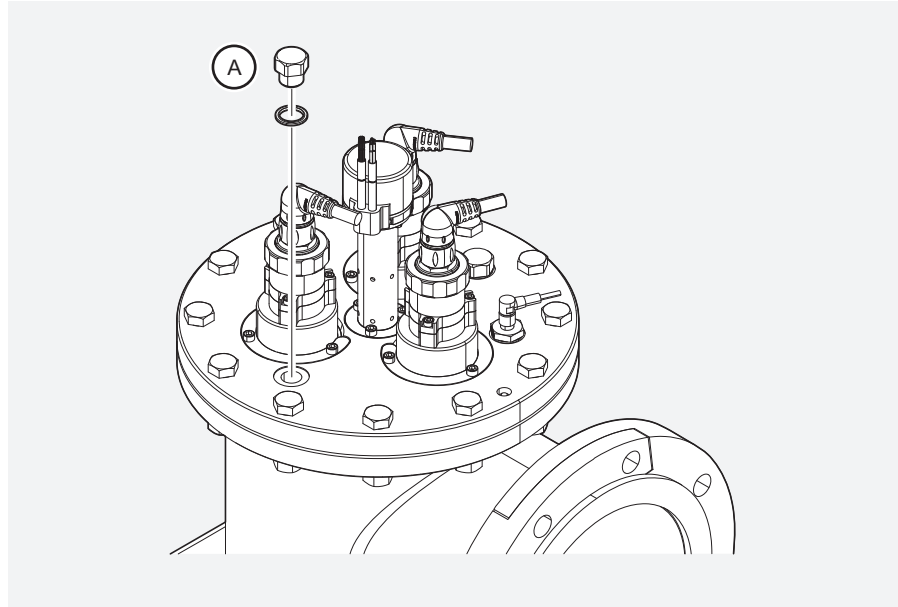

2. Open the aeration plug (A).
3. Open the inlet valve of the unit until water emerges from the bleed point.
4. Close the aeration plug (A).
5. Open the outlet valve of the unit.

## 8 Uninstall

### 8.1 Uninstalling the system

1. Turn off the system, see "Turning off" on page 22
2. Disconnect the mains power to the control panel.
3. Close the inlet and outlet valves to the AquaWorker.
4. Drain the AquaWorker.  
See "Draining the AquaWorker" on page 53
5. The unit is now prepared to be disconnected from the piping system. Rinse the reactor with fresh water before storage or other handling of the unit.

## 9 Troubleshooting

### 9.1 Alarm list

**NOTE**

Hard alarms WILL shut down the AquaWorker.  
Soft alarms will NOT shutdown the AquaWorker.

Soft alarms only informs that service is required.

#### 9.1.1 Hard alarms

Text Content Hard Alarms	Description	Failure mode	Remedy
Reactor temperature high	Temperature in the reactor >65°C GT2	Low flow, closed valves (V1/V2)	-
External off activated	External user has switched off the machine.	-	-
Cabinet temp high >45°C	Temperature in cabinet >45°C FC	Clogged fan filters, fan stopped. Ambient temperature is too high.	-
Main relay off	Main relay to LPS is off.	GT2 tripped or PLC tripped.	-

#### 9.1.2 Soft alarms

Text Content Soft Alarms	Description	Remedy
LPSx Error shutdown	Operation was terminated or the lamp could not be lit.	-
LPSx Power Protection	Operation was terminated due to lamp power outside the given limits.	-
LPSx Temperature Protection	Operation was terminated due to high lamp power supply temperature.	-
LPSx Lamp Voltage Error	Operation was terminated due to arc voltage outside of the given limits.	-
LPSx Ballast Under Voltage	Operation was terminated due to under voltage condition at mains.	-
LPSx Ballast Mains Error	Ballast has cut mains connection, or the fuse has tripped.	-

<b>Text Content Soft Alarms</b>	<b>Description</b>	<b>Remedy</b>
LPSx Ground Fault	Ballast cut connection to mains due to detection of ground fault.	-
LPSx Preheat Error	Ballast stopped preheating and aborted starting of this lamp.	-
Quartz sleeves clean time	See "Quartz sleeve cleaning" on page 24 and follow the instruction.	-
Lamp 1 to 3 need replace	1000h left until lamp needs to be replaced.	-

## 10 Spare parts

All spare part orders must include the following information:

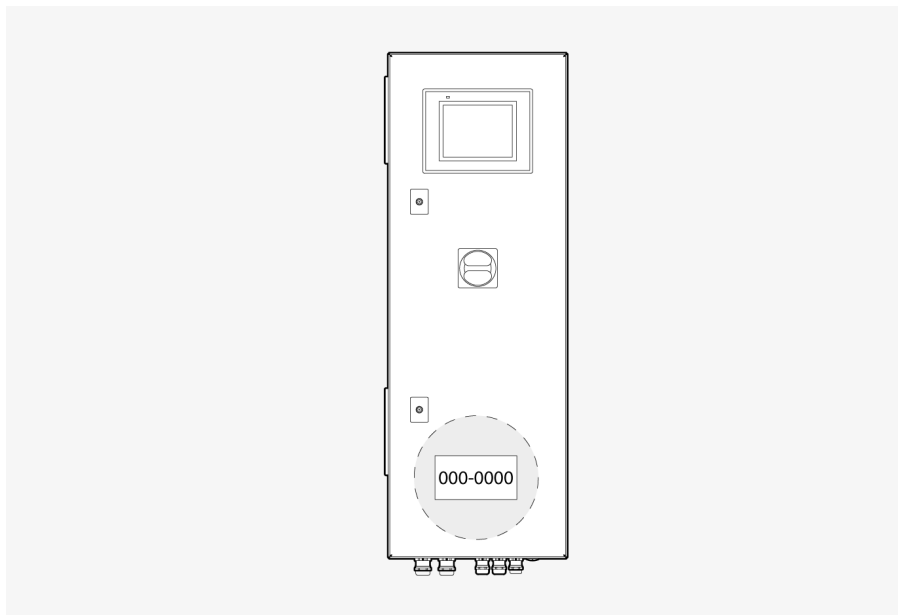

*The serial number is located on the inside of the control panel.*

- the AquaWorker serial number.
- the article number of the spare part if it is visible.
- the spare part description (name).
- ordered quantity.

# 10.1 Spare parts list

The spare parts list below include the most commonly used and ordered items. For other parts, please contact your distributor.

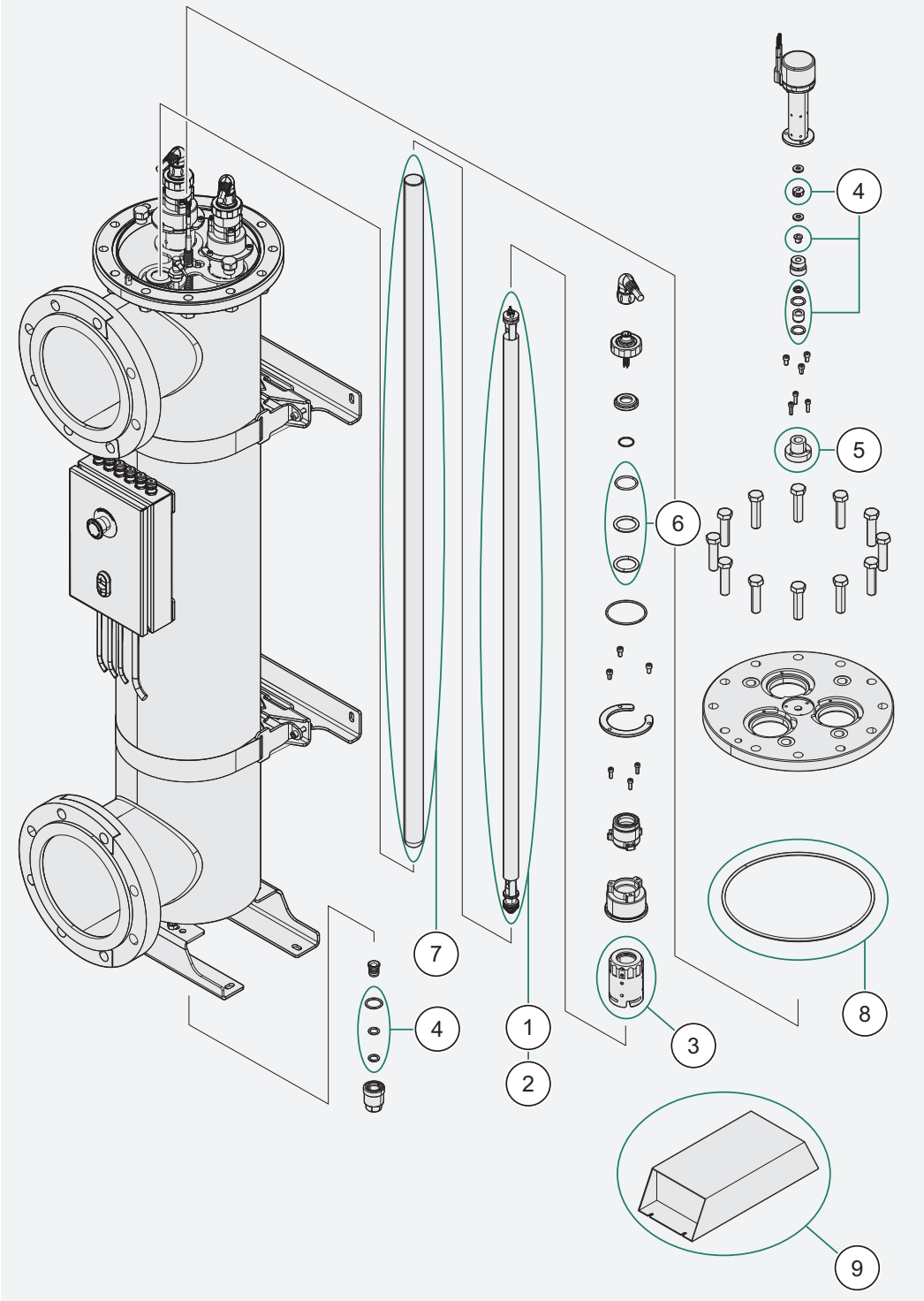

## Filter replacement

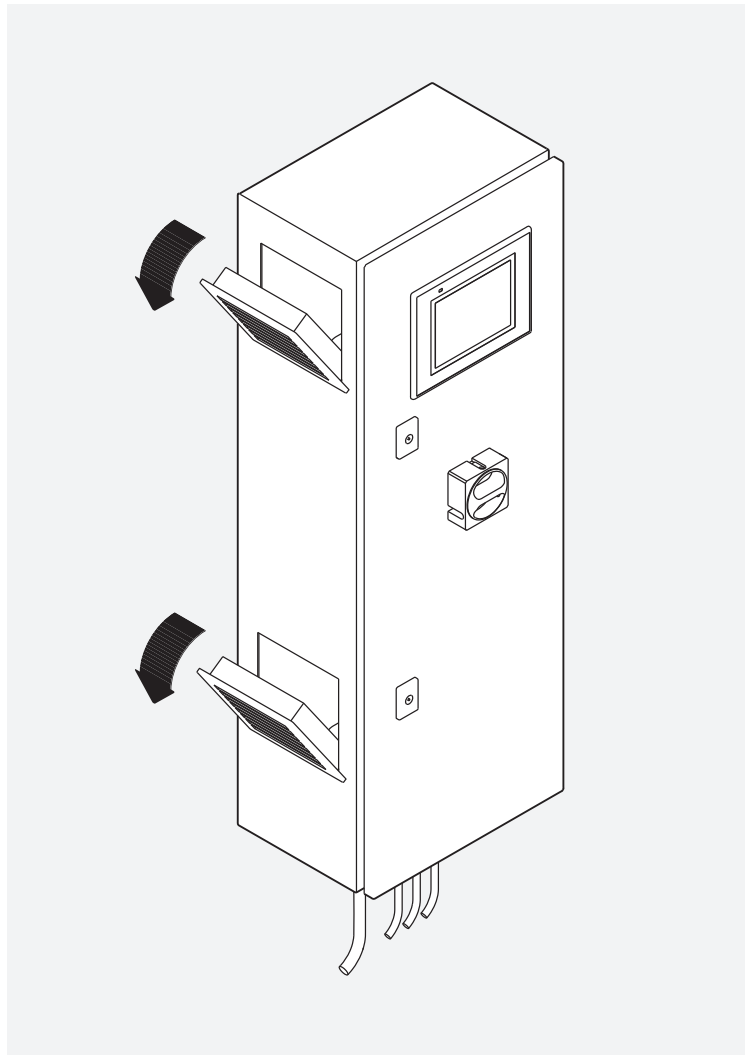

1. Pull the fan and filter cover until open.
2. Verify that the filter is free from excessive dust, and that it is intact.
3. Replace the filter if needed.

## Spare parts

No	Part number	Description	Recommended service interval
1	39-01-0100	UV lamp, 1 pcs (AquaWorker 300/310)	Max 16 000h
2	39-01-0101	UV lamp, 1 pcs (AquaWorker 320/330)	Max 16 000 h
3	39-01-0110	Cleaning kit (3 pcs of cartridge assembly)	16 000 - 64 000 h*
4	39-01-0104	Bearing and sealing kit, complete	8 000 - 32 000 h*
5	39-01-0108	Lead screw nut	16 000 - 64 000 h*
6	39-01-0106	Sealing kit, lamp top	On request
7	39-01-0102	Quartz sleeve, 1 pcs	On request
8	39-01-0107	O-ring, top plate	On request
9	39-01-0099	Lamp power supply (LPS)	On request
10	39-01-0130	Air filter	On request

\* Service interval depends on cleaning cycle frequency (Low, medium, high).  
See HMI, screen 133



# 11 Specifications

## 11.1 Technical specifications

SYSTEM	AquaWorker 300/320		AquaWorker 310/330	
	Without automatic cleaning system		With automatic cleaning system	
Number of UV lamps	3			
Total lamp power	Max. 1050 W			
Total power consumption	Max. 1200 W			
Water temperature	5..40°C			
Max flow rate	250 m <sup>3</sup> /h			
Automatic cleaning system	No		Yes	
Drainage	Yes			
Temperature sensor	Yes			
Service timer	Yes			
Lockable On/off switch	Yes			
On/off via external switch	Emergency stop			
REACTOR				
Volume reactor	83 litres			
Weight reactor (empty / filled)	66 / 150 kg		71 / 155 kg	
Material reactor	Titanium, Gr 2			
Pressure class	PN10			
Dimensions in- and outlet pipe	DN200, EN 1092-1			
Temperature control	Thermo switch, EN 1.4571 (316 Ti)			
Sealing	FPM (Viton®)			
Protection class	IP65		IP54	

<b>SYSTEM</b>	<b>AquaWorker 300/320</b>	<b>AquaWorker 310/330</b>
Ambient relative humidity, reactor	up to 100% condensing	
<b>CONTROL PANEL</b>		
Weight control panel	18 kg	
Chassis material	Painted steel (RAL7035)	
Protection class	IP 54	
Ambient operating temperature	5..40°C	
Ambient relative humidity	10-90%, non-condensing	
Power input	230V +/-10%, 50/60 Hz, 10A or 400V +/-10%, 50/60 Hz, 16A	
Standard wired output	Potential free relay for alarm	
HMI	5.7" colour touch screen	
Weight including packing material	Approx. 170 kg	
Exterior dimensions (W x D x H)	600 x 800 x 1850 (mm)	
Minimum service distance for lamp replacement	1600 mm	
Max cable length Control panel <-> Reactor	30 m	

## 11.2 Dimensions

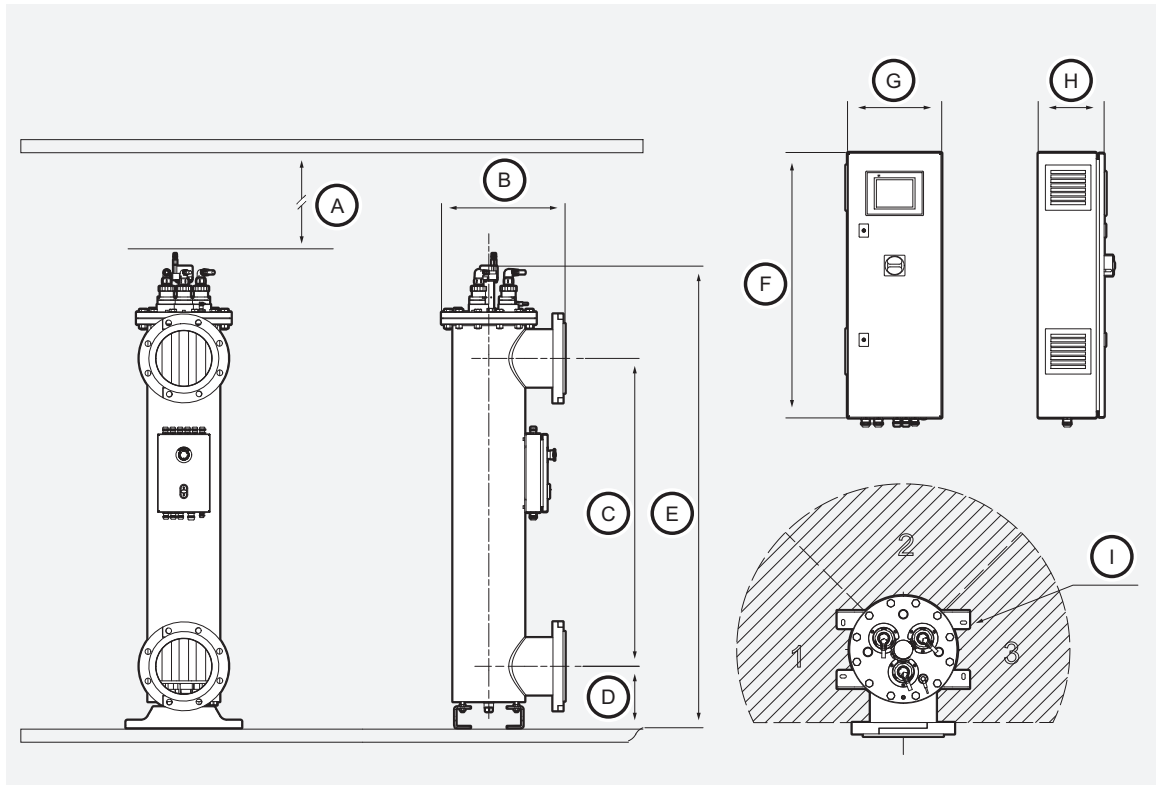

Dimension	Description	Value
A	Service space <sup>1</sup>	MIN. 1600 mm
B	Max width	470 mm
C	C-C Inlet/Outlet	1180 mm
D	Floor distance	240 mm
E	Total height	1750 mm With cleaning system 1770 mm
F	Electrical cabinet height	850 mm
G	Electrical cabinet width	300 mm
H	Electrical cabinet depth	210 mm
I	Accessibility space <sup>2</sup>	MIN. 300/600 mm

<sup>1</sup> Minimum distance to ceiling or wall, dependig on installation, for service.

<sup>2</sup> One of the zones 1-3 should fulfill the larger dimension measured from the center of the reactor.

## 11.3 Tightening torque

Following table can be used as a guide of safe torque values for specific fasteners used in AquaWorker. Fasteners in the table are more or less frequently used during service and maintenance.

Description	Size	Torque (Nm)	Strength class
DN200 Flange bolts	M20	420	8.8
Top plate bolts	M16	210	8.8
Thermo switch/plugs	G½"	87	8.8
Top cap/pressure plate screws Motor stand screws	M6	11	8.8
Top hub – lamp top screws	M5	6	8.8
Shaft collar screws	M3	1.4	8.8

### NOTE

Lubrication is required for all M5 and M6 Bolts.

If threads are lubricated before assembly, the torque values can be reduced by approx. 10%.

Recommended thread lubricants (can be used for all screws in AquaWorker) are for example:

- Loctite Heavy Duty Anti-seize
- Loctite 8009
- Loctite 8023  
or other lubricants with similar compound.

# A Appendix

## A.1 Automatic control system

### NOTE

Read this chapter carefully to learn about the screen control system.

This chapter gives a basic understanding of the functions in the screen based control system of the AquaWorker.

### A.1.1 Screens – General functions

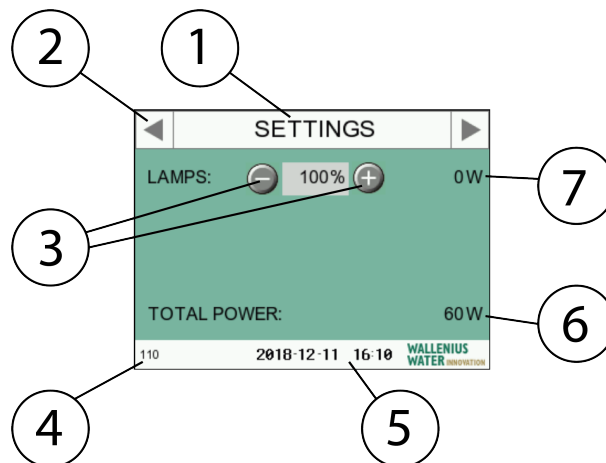

1. Shows the title of the selected screen.  
This informs what function the screen has.
2. Use the arrows to navigate through the screens.
3. On some screens it is possible to alter the settings on different parameters.  
Use the - /+ buttons to reduce or increase the value.
4. Shows each screens unique number.
5. Shows the Date and time used for the units logging function.
6. Shows the total power consumption of the unit.
7. Shows the current power consumption of the lamps.  
In the image above, the lamps are turned off.

## A.1.2 Screen 100 - Main

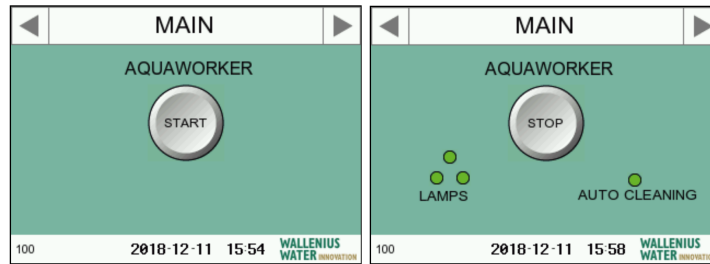

*Startup – The unit is waiting for command (left).*

*Normal operation, lamps are lit and cleaning system active (not in sequence) (Right).*

When unit's power is turned on the unit performs an automatic cleaning before the lamps are lit.

1. The unit is waiting for user command.
2. An automatic cleaning sequence is activated and a progress bar shows the status of the cleaning.
3. When the automatic cleaning sequence is finished, the lamp ignition is started, and the progress is shown on a progress bar.
4. When the unit is running, only lamp status and automatic cleaning status are shown on the Main screen.

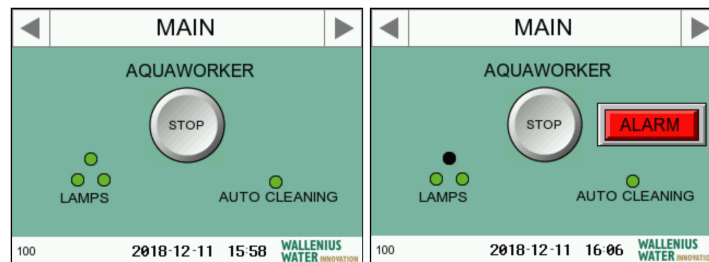

The **ALARM** button appears on the Main screen when an alarm occurs. Press the **ALARM** button and read more about the alarm on screen 20, "Screen 120 - Alarm History" on the next page. See chapter "Alarm list" on page 56 for more information about soft and hard alarms.

### A.1.3 Screen 110 - Settings

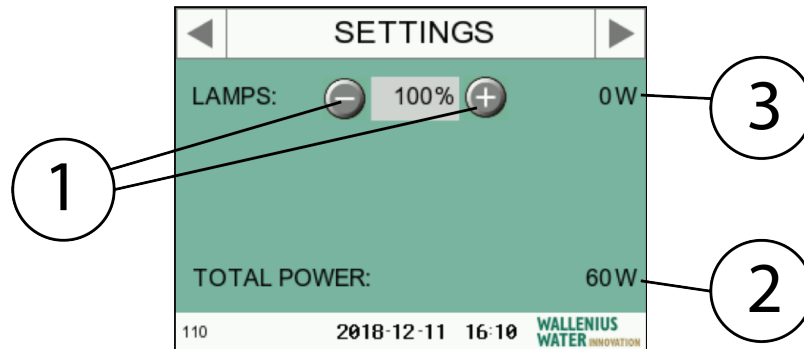

Screen 110 - Settings

1. Reduce or increase the intensity of the Lamps. Percentage of total rated power.
2. Shows the total power consumption of the unit.
3. Shows the current power consumption of the lamps. In the image above, the lamps are turned off.

### A.1.4 Screen 120 - Alarm History

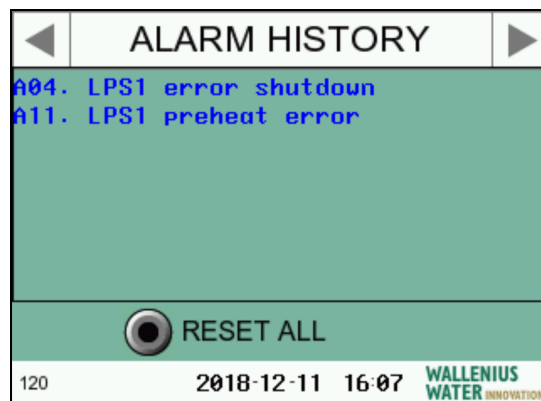

Screen 120 - Alarm history

On this screen all detected alarms are shown. The normal procedure to handle alarms is:

1. Read the alarm text.
2. Correct the error that caused the alarm. See the "Alarm list" on page 56
3. Press the *RESET ALL* button to reset the alarms.

## A.1.5 Screen 130 – Maintenance

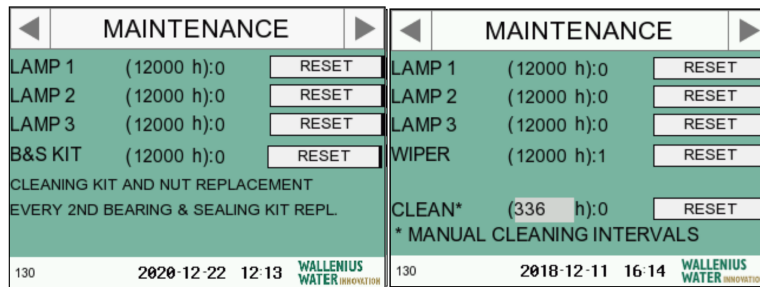

Screen 130 - Maintenance

This screen gives information about how many hours each component has been running.

If the unit does not have a automatic cleaning wiper or the wiper function is disabled then this screen also shows the manual cleaning interval.

When a manual cleaning is performed then the user should push the corresponding RESET button.

### NOTE

Pressing Reset is NOT REVERSIBLE.  
The counter cannot be recovered.

When the service is completed, the service timers for the lamps and wiper can be individually reset. Press the *RESET* button each time a component is replaced.

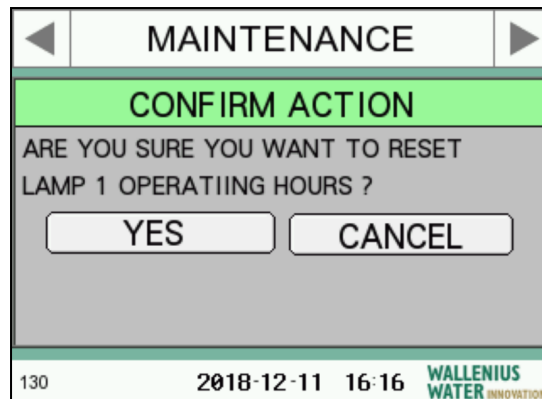

Screen 130 - Maintenance and confirmation

When the *RESET* button is pushed a pop up window for confirmation will show. In this example the reset button for Lamp 1 has been pressed after lamp replacement.



### A.1.6 Screen 131 - User Interface

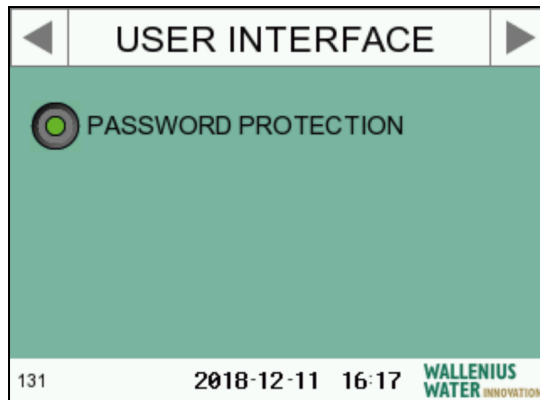

Screen 131 - User interface

On this screen the password protection can be disabled. When the password is enabled there will be a login screen when the user makes any changes to the system.

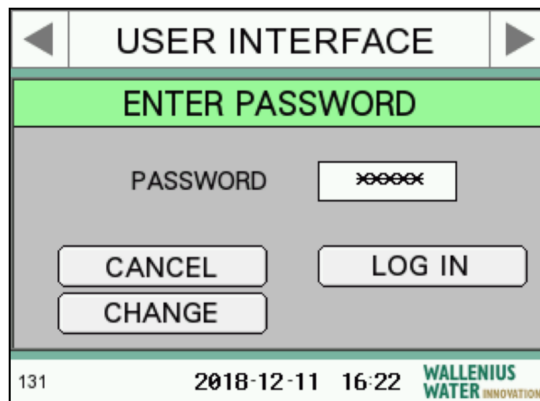

Screen 131 - Login screen

When the password protection is selected, it will be activated after 30 seconds.

User is already logged into the system.

When the user has logged in to the system there are no need for a second login activity during the next 6 minutes. After 6 minutes the user will be automatically logged out.

### A.1.7 Screen 133 - Auto cleaning (AquaWorker 310/330 only)

On this screen the user can select the needed cleaning intensity. The following information is shown on the screen:

- Bearing and sealing kit replacement interval
- Cleaning interval (auto or manual)
- Elapsed time since last cleaning

When elapsed timer has reached the cleaning interval an auto cleaning will be made or a message appears on the alarm screen if auto wiper is disabled.

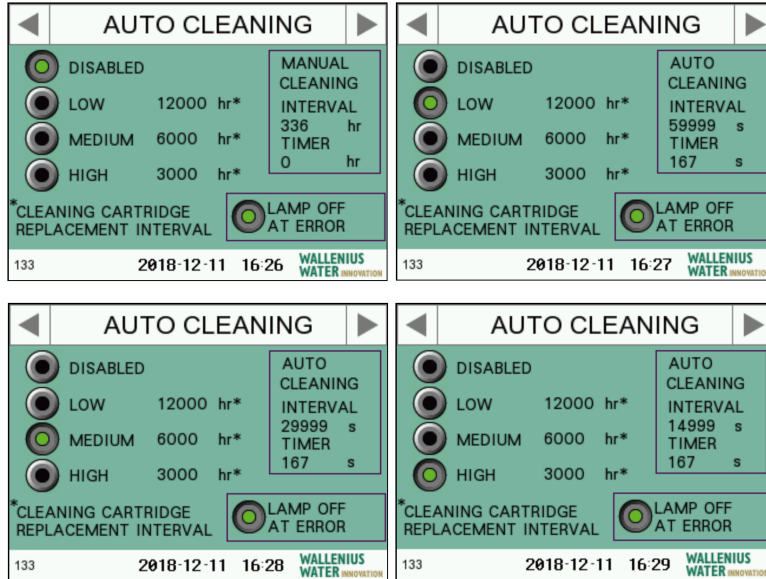

Screen 133 - Auto cleaning

The count-up timer is automatically recalculated by the system when settings are changed. When the timer reach the selected interval value, a cleaning cycle will be started.

### A.1.8 Screen Main - Service (AquaWorker 310/330 only)

The movement of the wiper system is indicated by arrows.

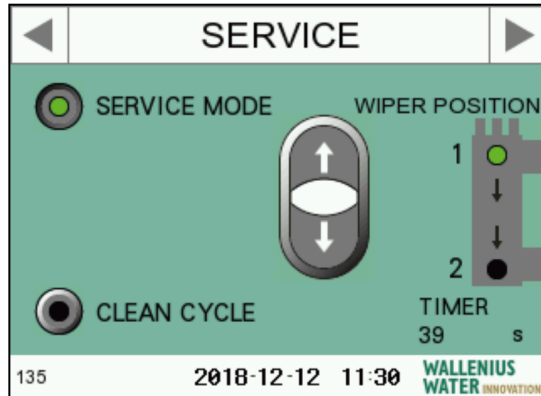

Screen 135 - Service, wiper position is recognized as position 1 by the system.

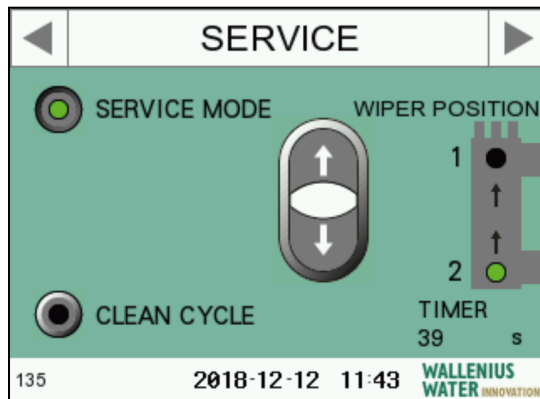

Screen 135 - Service, wiper position is recognized as position 2 by the system

### A.1.9 Screen 140 - Information

**NOTE**

Due to continuous work of software and hardware, please note the version number on this screen for any communication for identification.

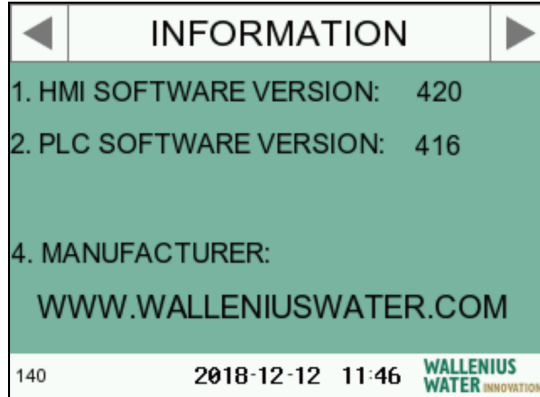

*Screen 140 - Information*

## A.2 Site acceptance test (SAT)

Check step 1-7 in the tables below and document the results before turning on the system. See "Troubleshooting" on page 56 for any non-approved steps. Abort the installation and contact your local distributor if the installation is still not approved.

### Site acceptance test performed:

Test date:

---

Test location:

---

Before starting the system	Approved	Not Approved	Comments
1. Is the unit properly fixated on a rigid and solid wall or stand.  Yes: Approved			
2. Is the electrical cabinet installed according to specification? See "Specifications" on page 62, Ambient humidity / temperature.  Yes: Approved			
3. Are the cables between the electrical cabinet and the terminal box properly routed and fixated? See "Electrical installation" on page 17.  Yes: Approved			
4. Is the mains cable to the electrical cabinet installed according to requirements? See "Electrical installation" on page 17.  Yes: Approved			

Before starting the system	Approved	Not Approved	Comments
5. Is the unit levelled according to installation requirements? See "Connecting the AquaWorker" on page 13.  Yes: Approved			
6. Are the UV lamps installed according to chapter "Install UV-lamps" on page 15 ?  Yes: Approved			
7. Are the loose flanges assembled to the reactor?  Yes: Approved			
8. Are the flange protections removed?  Yes: Approved			
9. Are the connected pipes/valves properly fastened?  Yes: Approved			
10. Has the unit has been filled and bled? See "Filling and bleeding the AquaWorker" on page 54  Yes: Approved			
11. During fill-up of the unit, are any leakages detected?  No: Approved			
If all steps above are approved, go to chapter "Starting up" on page 20			

System start up and operation	Approved	Not approved	Comments
12. Does the touch display turn on and show the screen named "START UP SCREEN", without changing to screen "MAIN" then the Ethernet cable in the cabinet is not correct connected.			

<b>System start up and operation</b>	<b>Approved</b>	<b>Not approved</b>	<b>Comments</b>
<p>13. Does the touch display turn on and show the MAIN screen when the main switch is turned on?</p> <p>Yes: Approved</p>			
<p>14. Are any soft alarms active? Check the MAIN screen if the ALARM button is visible.</p> <p>No: Approved</p>			
<p>15. Is the cleaning system functioning? On the AUTO CLEANING screen press AUTO CLEANING (the operation starts with one cycle).</p> <p>Yes: Approved</p>			
<p>16. Do all the lamps work? Check the lamp symbols on the MAIN screen.</p> <p>Yes: Approved</p>			
If all steps above are approved the system is working correctly.			

### A.3 Maintenance Record

Date	By	Action	Comments/Notes



## A.4 Connection terminal list

X1 Terminal Numbering	Function	Voltage
L1	Main power input	400VAC
L2	Main power input	400VAC
L3	Main power input	400VAC
N	Main power input	Neutral
PE	Protected Earth input	Protected Earth

X2 Terminal Numbering	Function	Voltage
1	Do not connect	+24VDC
2	Do not connect	0VDC / GND for 24VDC signals.
3	Do not connect	0-10VDC analogue signal input.
4	Do not connect	0VDC / GND for 24VDC signals.
5	Do not connect	0VDC / GND for 24VDC signals.
6	Remote system alarm	Common, Potential free relay, external alarm system.
7	System run	NO, Potential free relay, external alarm system.
8	System Soft Alarm	NO, Potential free relay, external alarm system.
9	System Hard Alarm	NO, Potential free relay, external alarm system.
10	Users NC switch ON-OFF	NC, is used for customer to remote OFF system.
11	Users NC switch ON-	NC, is used for customer to remote OFF system.
12	0VDC	0VDC / GND for 24VDC signals.
13	Wiper enabled	0VDC/+24VDC. Connect wire between X2:12 and X12:13 if wiper exist on product.
14	Not Used	

<b>X3 Terminal Numbering</b>	<b>Function</b>	<b>Voltage</b>
31	PLC input: S2 response	+24VDC
32	M1: Power – 0VDC	+24VDC/+48VDC
33	M1: Power – 48VDC	+48VDC
34	M1: Analogue – 0VDC	+24VDC
35	M1: Logic – 24VDC	+24VDC
36	M1: InA	+24VDC
37	M1: InB	+24VDC
38	M1: In1	+24VDC
39	M1: In2	+24VDC
40	M1: Out1	+24VDC
41	M1: Out2	+24VDC
42	S1: Up	+24VDC
43	S1: Down	+24VDC
44	S1: H1	+24VDC
45	S2: NC_1	+24VDC
46	S2: NC_2	+24VDC

## A.5 Electrical drawings

---

50-0040 Cabinet layout_1 .....	81
50-0040 Cabinet layout_2 .....	82
50-0039 Main Power_1 .....	83
50-0039 Main Power_2 .....	84
50-0043 Electrical connections .....	85
50-0044 Juntion box layout .....	86
50-0039 PLC_I_O .....	87

1 Mounting plate

2

3 Front view

4

5 Inside view

6

7 Back view

8

9 Left view

10

Bottom view

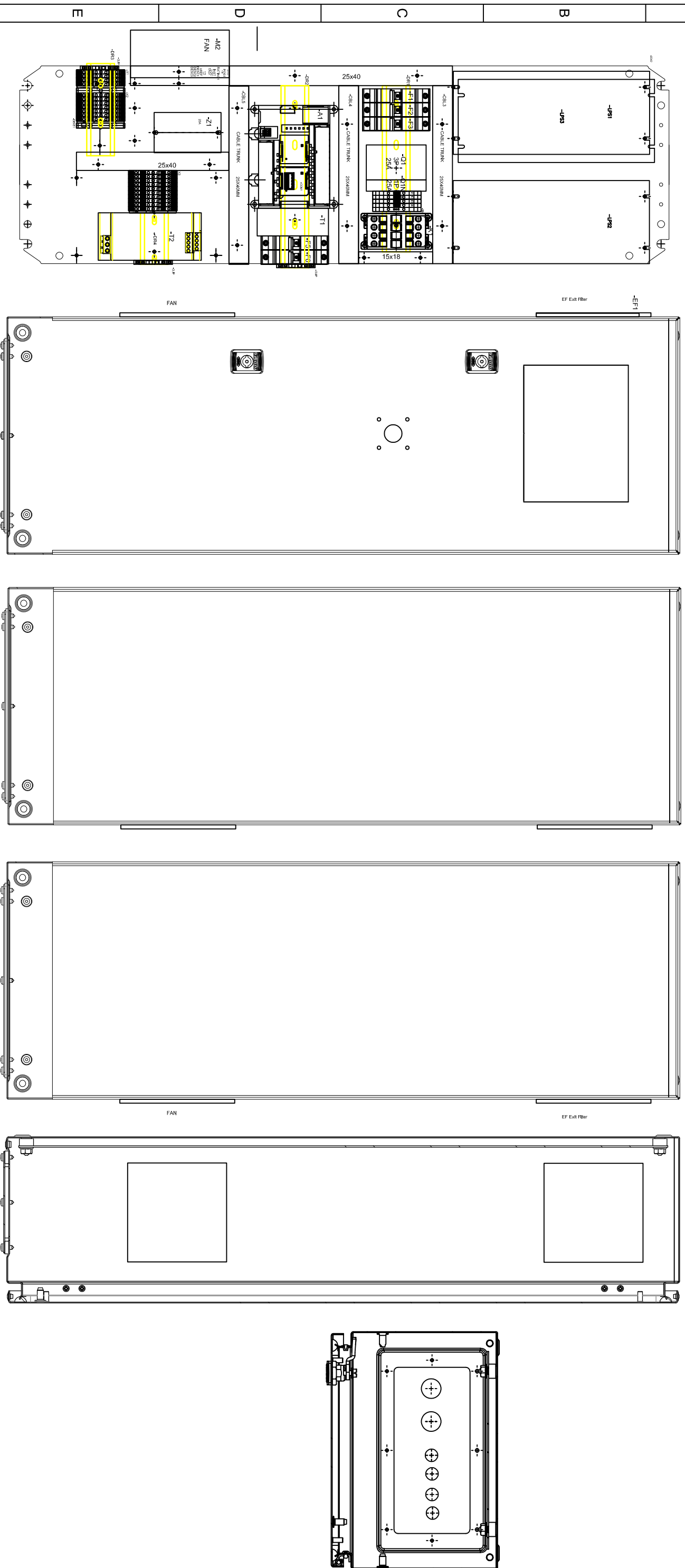

Title  
AquaWorker  
Electrical cabinet  
Layout

**WALLENIUS**  
**WATER INNOVATION**  
Drawing Type  
Circuit Diagram

Note

First angle projection Method ISO E	Status Released	Date 2016-12-14	Sheet 001 ( 002)	Scale 1:1	Revision 8
	Creator OWMIDE	Checked by OWMIDE	Approved	Document No. 50-0040	

Rev 2	Revised owdidr	Date 2017-12-01	Description new loggo WWI	Approved owmide
-------	----------------	-----------------	---------------------------	-----------------

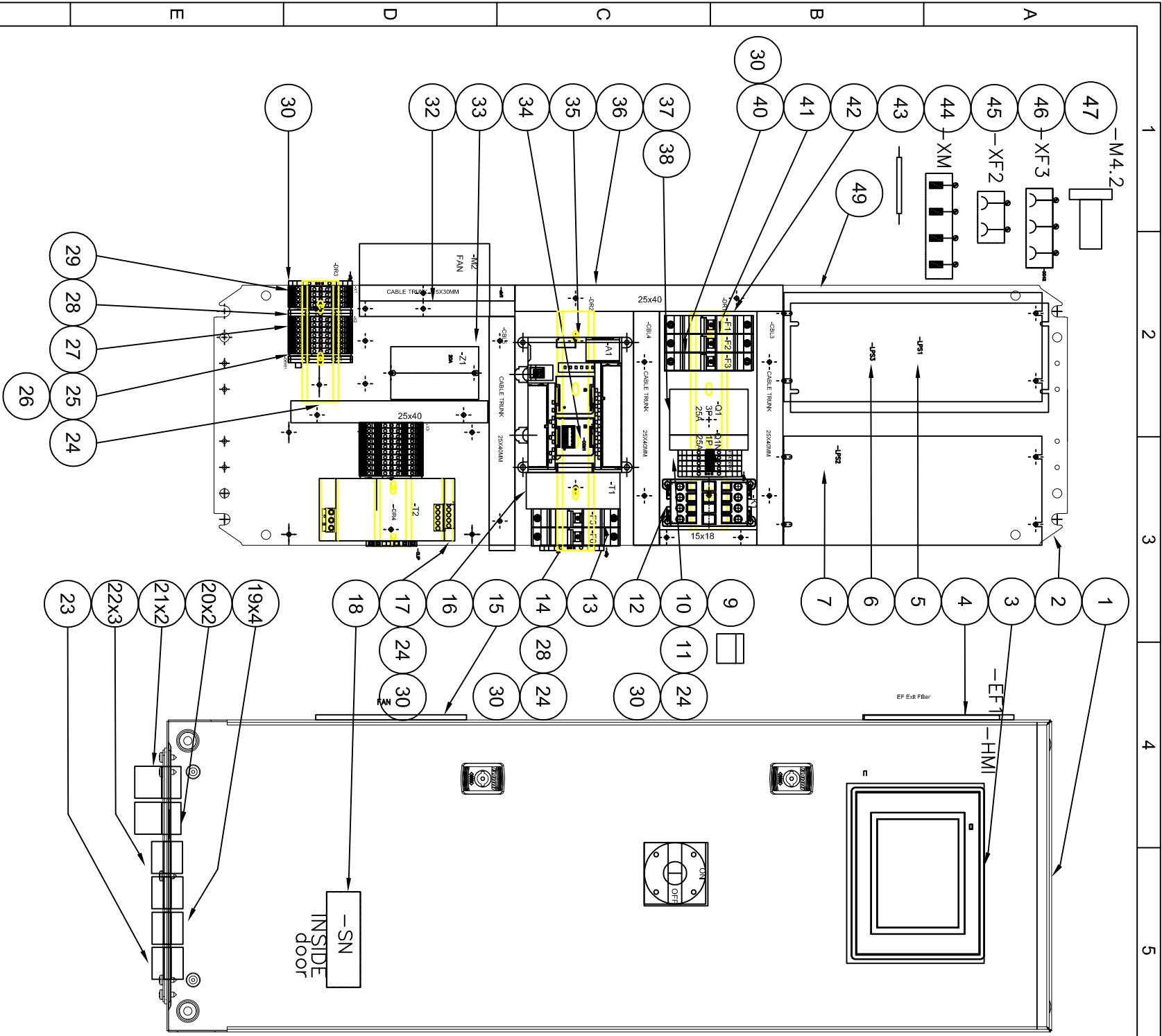

NOTE: ALL THE TERMINALS IS NEEDED TO TIGHTEN ACCORDING TO WI-0082

CBL	SH	L(m)	MFG	CAT/ArtNo	REF	DESC1	CONNECTED FROM
W2	1	12	ANY	1,5MM2 BLACK		flex,stranded,pvc,1000V	230VAC
W3	1	4	ANY	1,5MM2 BLUE		flex,stranded,pvc,1000V	230VAC
W5	2	6	ANY	0,75MM2 BLACK		flex,stranded,pvc,1000V	230VAC
W6	2	6	ANY	0,75MM2 DARKBLUE		flex,stranded,pvc,1000V	0VDC
W10	3	1	Weidmuller	1248280010		RJ45 0/90 degrees	PLC-HMI
W11	3	3		5576749		FTP Twisted pair, shielded	
W12	1	5	ANY	0,75MM2 GREY		flex,stranded,pvc,1000V	+24VDC
W14	1	5	ANY	0,75MM2 LIGHTBLUE		flex,stranded,pvc,1000V	230VAC
W15	3	1	ANY	0,5MM2 GREY		flex,stranded,pvc,1000V	+24VDC
W16	3	1	ANY	0,5MM2 DARKBLUE		flex,stranded,pvc,1000V	0VDC

POS	QTY	TAGS	DESCRIPTION	DOC. NO
1	1		CABINET	112882
2	1		Mounting plate	113831
3	1	HMI	TOUCH PANEL	
4	1	EF1	EXIT FILTER	
5	1	LPS1	BALLAST	
6	1	LPS2	BALLAST	
7	1	LPS3	BALLAST	
8				
9	1		Usb for HMI	
10	4	N1-N4	WDU2.5BL(term)	
11	1		WQV2.5/4(bridge)	
12	1	K1	RELAY	
13	1	F5	FUSE	
14	1	F6	FUSE	
15	1	M2	FAN	
16	1	T1	AC/DC, 24VDC/2.5A	
17	1	T2	AC/DC, 48VDC/5A	
18	1		S/N Label	114189
19	4		M16x1,5 NUT	
20	2		M20x1,5 NUT	
21	2		M20x1,5 CBL	
22	3		M16x1,5 CBL	
23	1		M16 blindplug	
24	0,7 m		DIN RAIL	
25	3		WAP WDK2.5/4N	
26	1		DEK5 1-100	
27	17	X2-X3	WDK2.5N (term)	
28	2	PE	WPE4	
29	4	X1	WDK2.5NV	
30	5		END STOP	
31				
32	0,1m		CBL trunk 15x30	
33	1	Z1	RFI FILTER	
34	1		COMPORI	
35	1	A1	PLC	
36	1,2 m		CBL trunk 25x40	
37	1	Q1	MAIN SWITCH	
38	1	Q1N	NEUTRAL	
39				
40	1	F3	FUSE	
41	1	F2	FUSE	
42	1	F1	FUSE	
43	6		LPS bracket	
44	3	XM	LPS lamps	
45	3	XF2	LPS Modbus	
46	3	XF3	LPS Mains	
47	26		M4,2x9,5	
48	5	R1, R2	Resistor 4,7 Kohm,2W	
49	1	R6	Resistor 120 Ohm, 2W	

**Title**  
**AquaWorker**  
**Electrical cabinet**  
**BOM**

**WALLENIUS**  
**WATER INNOVATION**

Drawing Type

First angle projection Method ISO E	Status Released	Date 2016-12-14	Sheet 002 (002)	Scale 1:5	Revision 8
Creator OWMIDE	Checked by OWMIDE	Approved	Document No. 50-0040		

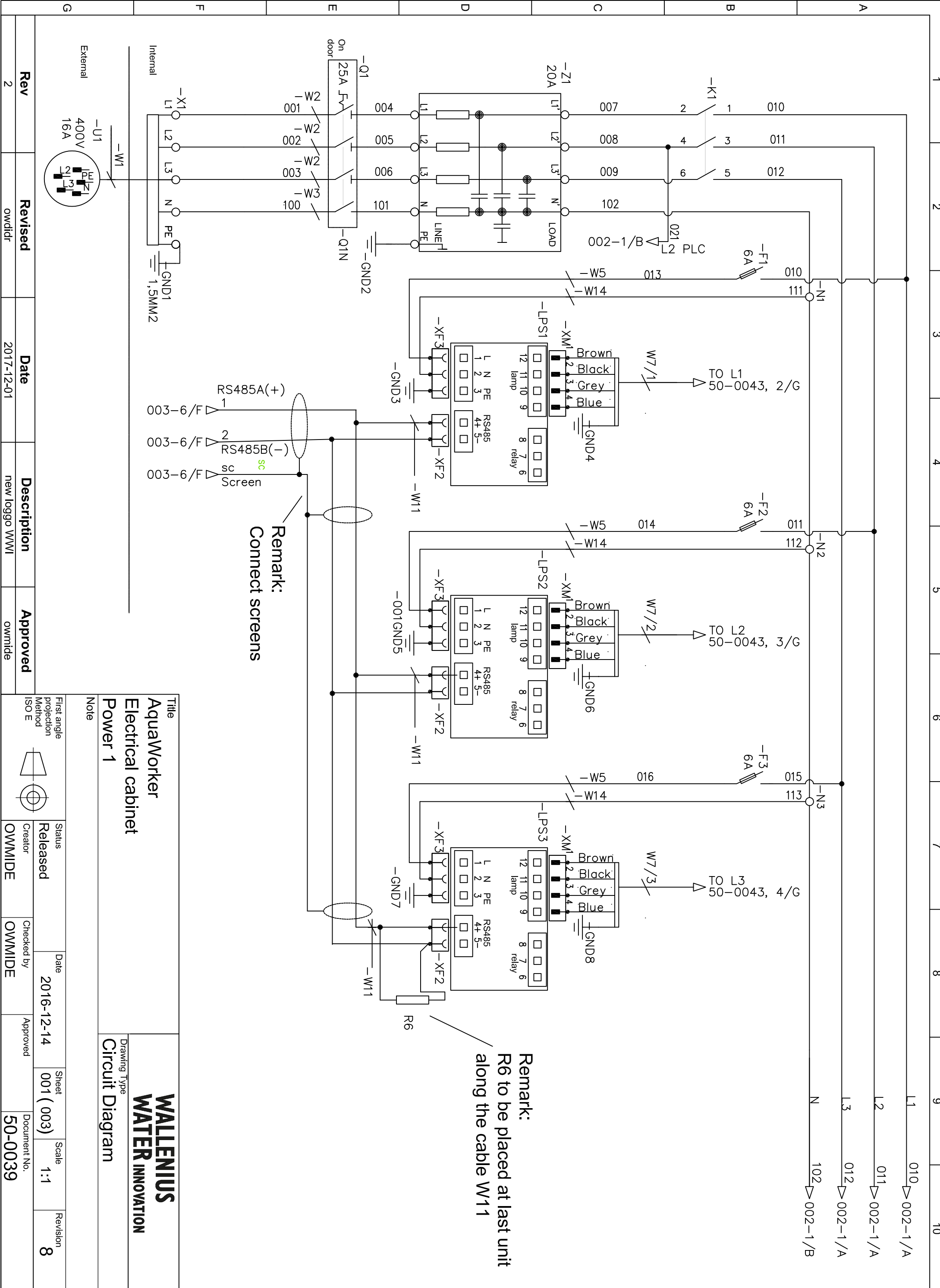

Remark:  
Connect screens

Remark:  
R6 to be placed at last unit  
along the cable W11

Title  
**AquaWorker**  
**Electrical cabinet**  
**Power 1**

WALLENIUS  
WATER INNOVATION

Drawing Type  
**Circuit Diagram**

First angle projection Method ISO E	Status	Date	Sheet	Scale	Revision
	Released	2016-12-14	001 (003)	1:1	8
ISO E	Creator	Checked by	Approved		
	OWMIDE	OWMIDE			
	Note				

Rev	Revised	Date	Description	Approved
2	owdidr	2017-12-01	new loggo WWI	owmide

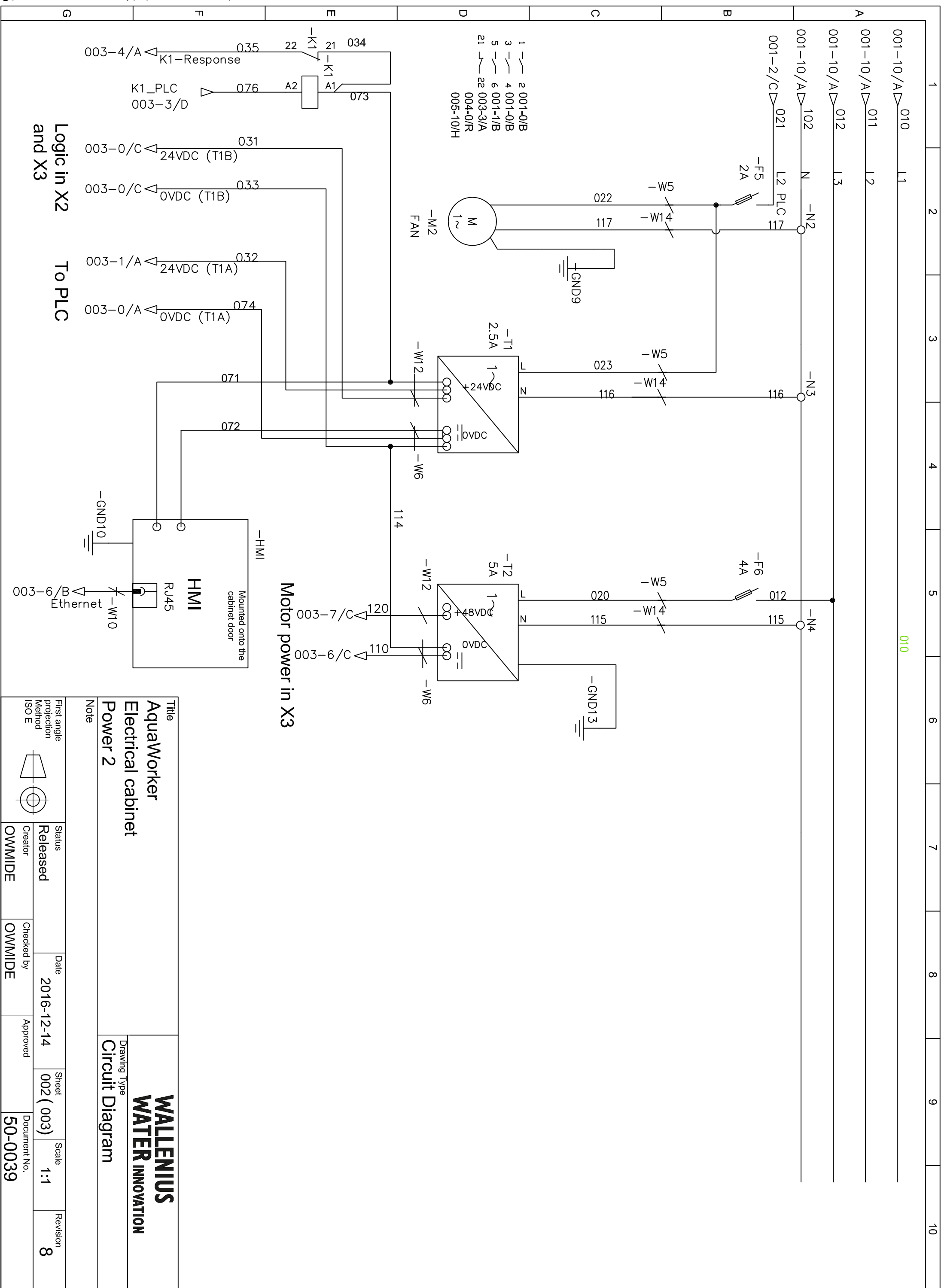

<b>Title</b> AquaWorker Electrical cabinet Power 2		<b>Drawing Type</b> Circuit Diagram	
<b>Note</b>			
<b>Status</b> Released	<b>Date</b> 2016-12-14	<b>Sheet</b> 002 ( 003 )	<b>Scale</b> 1:1
<b>Creator</b> OWMIIDE	<b>Checked by</b> OWMIIDE	<b>Approved</b>	<b>Revision</b> 8
<b>First angle projection Method ISO E</b>		<b>Document No.</b> 50-0039	

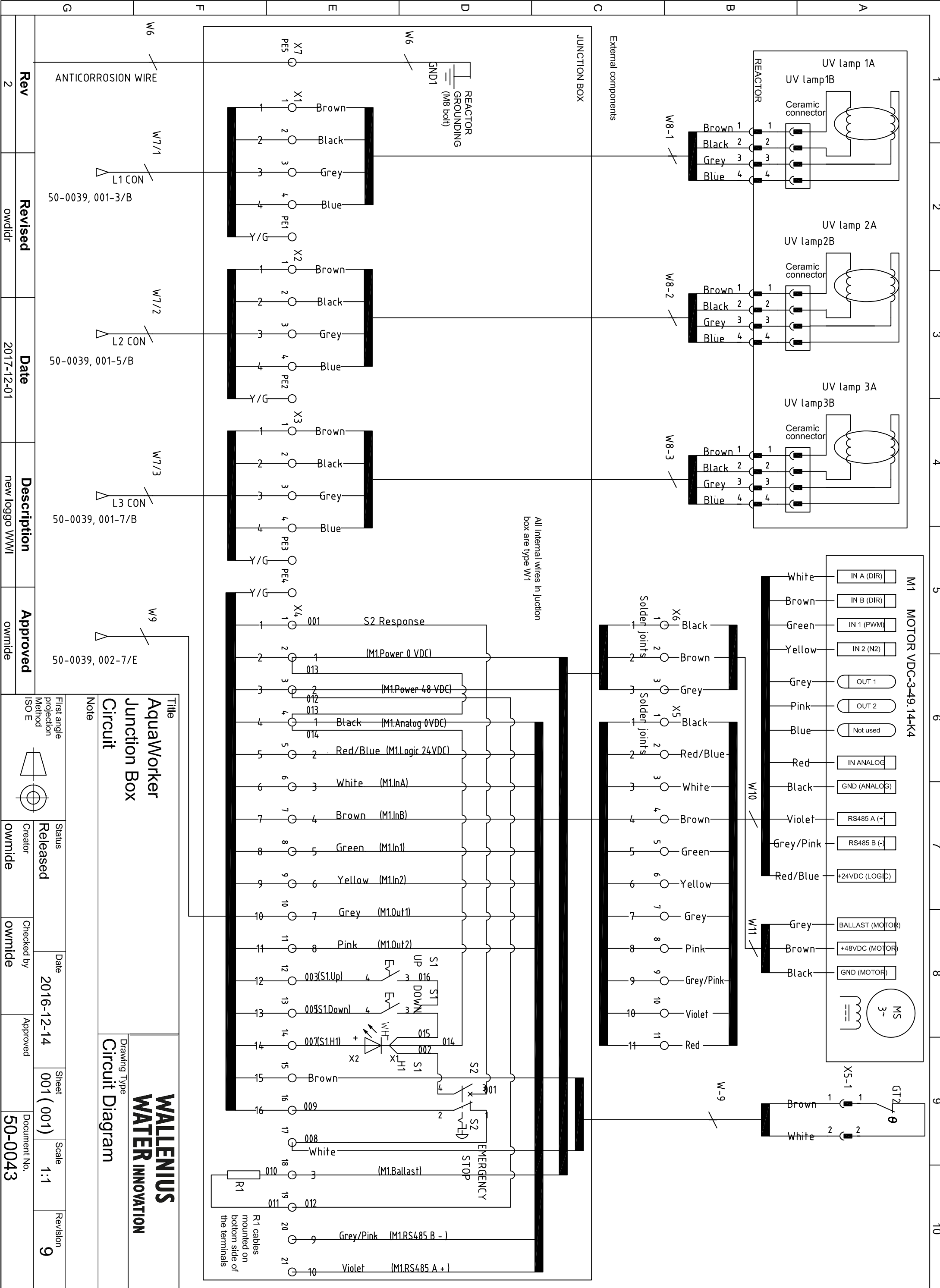

Rev	Revised	Date	Description	Approved
2	owdldr	2017-12-01	new loggo WWI	owmide

**Title**  
AquaWorker  
Junction Box  
Circuit

**Note**

**Drawing Type**  
Circuit Diagram

**Status**  
Released

**Date**  
2016-12-14

**Sheet**  
001 (001)

**Scale**  
1:1

**Revision**  
9

**Created by**  
owmide

**Checked by**  
owmide

**Approved**

**Document No.**  
50-0043



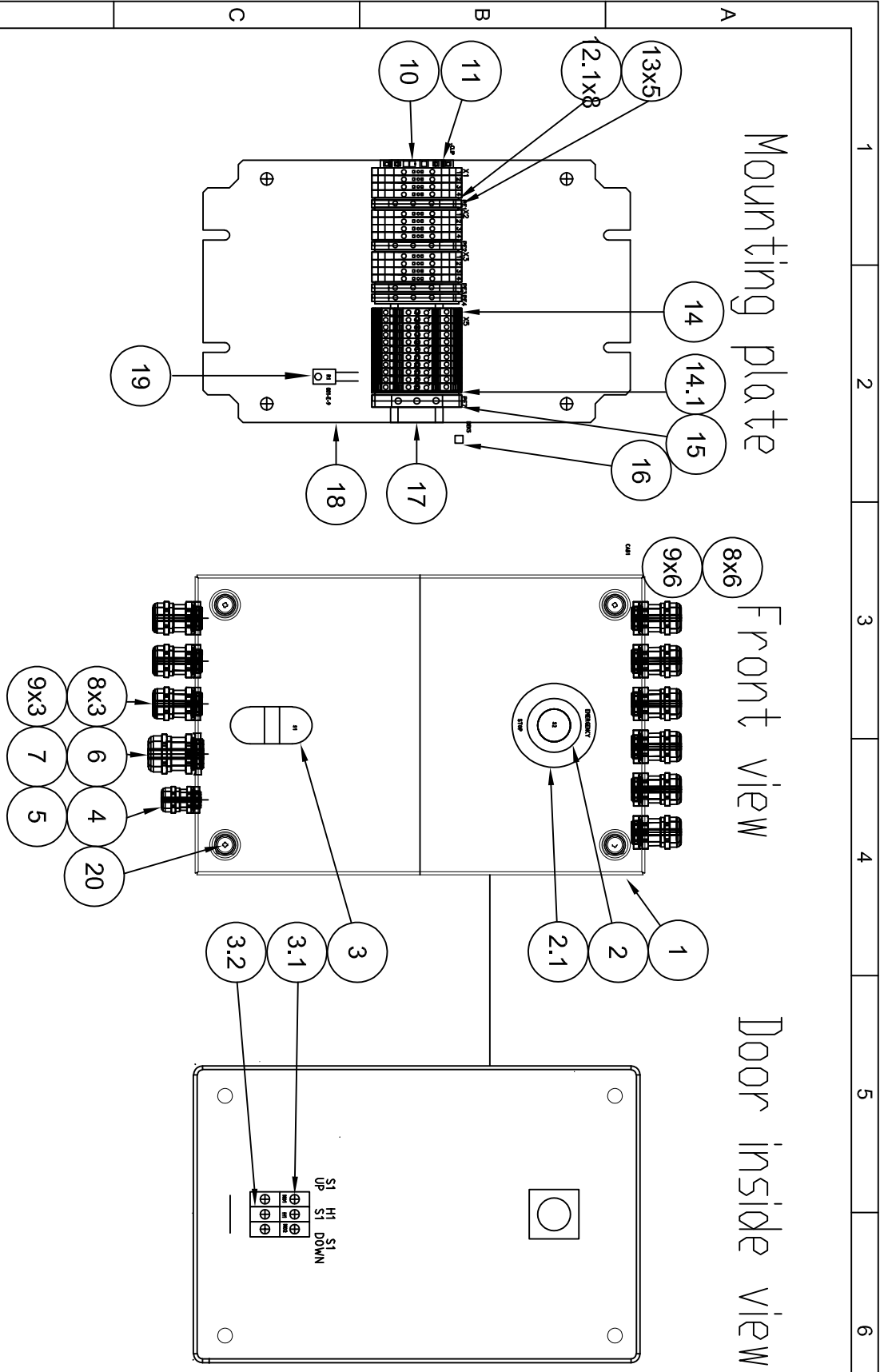

Pos	QTY	TAGS	DESCRIPTION	DOC. NO
1	1	CAB1	WALL MOUNT ENCLOSURE, IP66, DOOR, 300x200x80mm	113987
2	1	S2	Emergency Stop button, Latching function, 22mm, 1 NO+1 NC	
3	1	S1	UP DOWN Push Button Head Black Momentary, 22.5mm, OVAL BLACK, IP66	
3.1	2	NO1 NO2	NO CONTACT, make contact, Front mounting, 1NO, 6 A@ 230 V, AC15	
3.2	1	H1	LED element, 22mm, 18...30 VAC/DC, white	
4	1	M12	M12x1.5mm Cable Gland, Metric M12 Metal, METAL, Seal cable gland opening using rubber cylinder, dia = approx 6 mm	
5	1	M12 nut	M12x1.5mm Nut, Metric M12, METAL	
6	1	M20	M20 Cable gland, M20, Metal	
7	1	M20 nut	M20 NUT, M20, METAL	
8	9	M16	M16 CABLE GLAND, M16, METAL	
9	9	M16 plug	M16 NUT, M16, METAL	
10	1	STOP	END BRACKET - CLIPFIX 35-5, ACCESSORY - SNAP-ON END BRACKET, FOR NS35/7.5 OR NS35/15 DIN RAIL, 5.15MM WIDTH	
11	1	DIN	Mounting rail, TS 35, TS 35 x 7.5, with slot, Steel, galvanized, 2000 mm, 2m, TS35x7.5	*0
12	12	X1 X2 X3	TERMINAL BLOCK - WDU 2.5, FEED-THROUGH, 25AMPS DARK BEIGE WEMID, 600V, 22-12AWG, SERIE W - SCREW CLAMP	
12.1	3		END PLATE FOR - WAP 2.5-10 OR HARDWARE END PLATE, ORANGE, 1.5MM THICK, SERIE W	
13	4	PE1 -PE4	STANDARD DESIGN PROTECTIVE CONDUCTOR TERMINAL - WPE 2.5 GROUND TERMINAL	
14	11	X5	WDK 2.5N, MULTI-LEVEL, 20AMPS DARK BEIGE WEMID, 600V, 16-12AWG, SERIE W - SCREW CLAMP	
14.1	1		END PLATE/PARTITION - WAP, END PLATE DARK BEIGE WEMID, THICKNESS 1.5MM, USED W/ WDK 2.5N	
15	1	PE7	WPE 6 GROUND TERMINAL, GREEN/YELLOW WEMID, 20-8AWG SERIE W - SCREW CLAMP	
16	1	DEK5	TERMINAL MARKER 5X5, DEK 5 FS 1-50, 5x5 mm, WHITE	
17	1		MOUNTING PLATE, STEEL, 285x175mm	
18	1	R1	POWER RESISTOR, 6R8, 100W	
19	1		Screw + washer for R1 fastening	
20	4		SCREW MFX M6x20 A4, bits PZD-3 and washer 5x11x2.2 mm, black rubber	

Tightening torque table

TAGS	Torque (N.m)
X1-X5	0.4-0.6
PE1-PE5	0.4-0.6
PE6	0.8-1.6
S1 ring	3
S1 term	1.2
S2 ring	3
S2 term	1.2

Top view

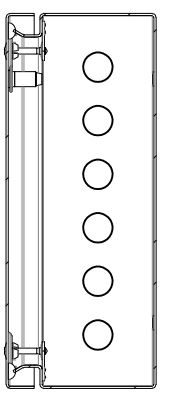

Bottom view

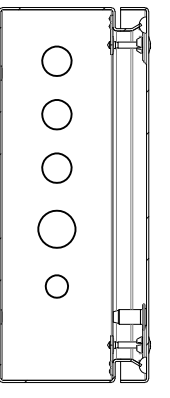

Obs! Only W1, W6 cables are related to this drawing(others refer to top assy)

CBL	SH	L(m)	REF	DESC1	CAT	MFG	ARTNO
W1	001	1	C-6	0.75mm2 grey	Stranded	ANY	AQ
W6	001	1	F-10	6mm2 GY	Stranded	ANY	AQ
W7/1	001	30	F-2	Lamp cable	5G 1.0	Miltronic	1119246
W7/2	001	30	F-3	Lamp cable	5G 1.0	Miltronic	1119246
W7/3	001	30	F-4	Lamp cable	5G 1.0	Miltronic	1119246
W8/1	001	1	B-1	Lamp connector	4x 1.5	Sourtau	HAUTSOV124RA100
W8/2	001	1	B-3	Lamp connector	4x 1.5	Sourtau	HAUTSOV124RA100
W8/3	001	1	B-4	Lamp connector	4x 1.5	Sourtau	HAUTSOV124RA100
W9	001	30	F-7	Signal cable	18G 1.0	Miltronic	1119249
W-10	001		B-7	Motor signal cable			
W-11	001		B-9	Temp Sensor cable			
W-12	001		B-5	Motor power cable			

**WALLENIUS WATER INNOVATION**

Title: AquaWorker Junction Box Layout/BOM

Note: First angle projection Method ISO E

Status: Released

Created by: owmide

Checked by: owldir

Date: 2016-12-14

Approved:

Sheet: 001 (001)

Scale: 1:1

Revision: 9

Document No.: 50-0044

Rev	Revised	Date	Description	Approved
5	OWMIDE	2018-03-13	Pos 20 added	OWMAAN

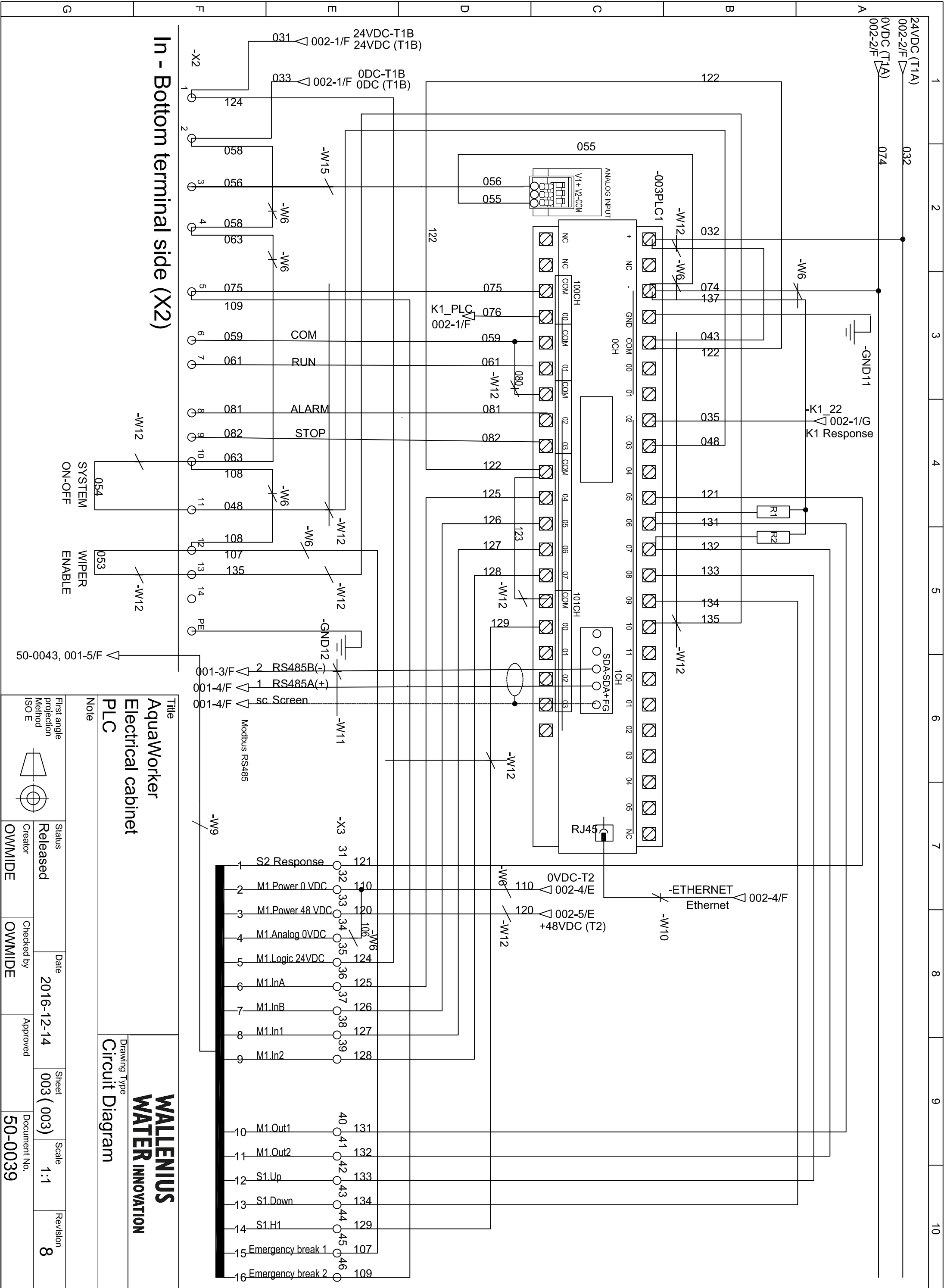

### In - Bottom terminal side (X2)

**Title**  
AquaWorker  
Electrical cabinet  
PLC

**Drawing Type**  
WALLENIUS  
WATER INNOVATION  
Circuit Diagram

**Note**

First angle projection Method ISO E	Status	Date	Sheet	Scale	Revision
	Released	2016-12-14	003 (003)	1:1	8
Creator	Checked by	Approved	Document No.		
OWMIDE	OWMIDE		50-0039		

## DECLARATION OF CONFORMITY

We,

Wallenius Water Innovation AB

Franzégatan 5  
SE-112 51 STOCKHOLM  
SWEDEN

declare under our sole responsibility that the products:

- AquaWorker 300—330
- Part no: 15-01-0109—15-01-0112
- Serial No: refer to type plate on respective unit

to which this declaration relates is in conformity with the following laws, standards or other named normative documents:

**Low Voltage Directive (LVD) 2014/35/EC:**

EN 60204-1:2006	Safety of machinery - Electrical equipment of machines
EN 60204-A1:2009	Safety of machinery - General requirement

**Directive of Electromagnetic Compatibility (EMC) 2014/30/EC:**

EN 61000-6-2:2005	Immunity for industrial environments
EN 61000-6-4:2007	Emission standard for industrial environments

**Machinery Directive 2006/42/EC:**

EN ISO 12100:2010	Safety of machinery - General principles for design
EN 60204-1:2007+ AC:2010	Safety of machinery - Electrical equipment of machines
EN ISO 13949-1:2008+AC:2009	Safety of machinery - Safety-related parts of control systems

Place and date of signature: Stockholm 2017-12-01

Signature of authorized person:

Typed name and function of the signatory: Ulf Arbeus, Vice President Products