

FluidWorker 100

Installation, Operation and Service Manual

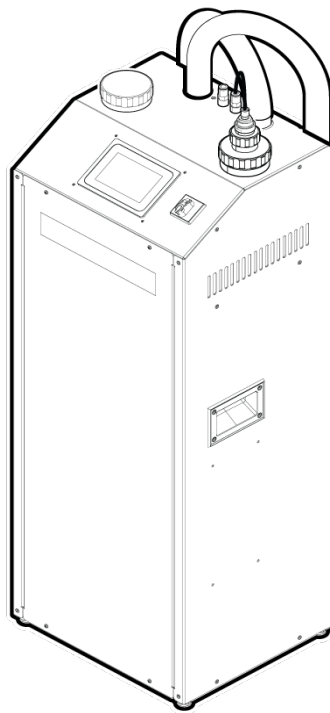

EN Original instructions

WALLENIOUS
WATER INNOVATION

Table Of Contents

1	General	1
1.1	Disclaimer	1
1.2	Warranty	1
1.3	Manufacturer	1
1.4	Service and support	2
1.5	Disposal	2
1.6	Validation	2
1.7	Acronyms and abbreviations	2
2	Safety	3
2.1	Warning, caution, and notes	3
2.2	General safety rules	3
3	Transportation	5
3.1	Unpacking	5
3.2	Delivery inspection	5
3.3	Inspection of UV lamp and quartz sleeve	6
4	System Description	8
4.1	Functional description	8
4.2	Control system	8
4.3	System overview	8
5	Installation	10
5.1	Before installation	11
5.2	Tools and materials	11
5.3	Connecting the FluidWorker 100	12
5.4	Electrical installation	17
6	Operation	18
6.1	Important information	18
6.2	Starting up	19
6.3	Turning off	20
7	Service and Maintenance	21
7.1	Lamp replacement	22
7.2	Quartz sleeve replacement	25
7.3	Strainer Inspection	29
7.4	Replacement of cleaning system components	33
7.5	Software/Firmware upgrade	37
8	Uninstallation	40
9	Troubleshooting	41
9.1	Alarm list	41
9.2	Hard alarms	41
9.3	Soft alarms	42
10	Spare parts	43
11	Specifications	44
11.1	Technical specifications	44
11.2	Motor, pump, lamp, and pressure combinations	46
11.3	Dimensions	47
A	Appendix	48
A.1	Connection terminal list	49
A.2	Automatic control system	53
A.3	Intermittent operation	63
A.4	Electrical drawings	64
	50-0054 FW100 Elconnections -11	65
A.5	Maintenance Record	67
	Declaration of conformity	68

1 General

Please read this manual carefully prior to installation and operation of the unit. Save these instructions for future use.

1.1 Disclaimer

Wallenius Water Innovation AB is not liable or bound by warranty if these instructions are not adhered to during installation, operation or service.

Wallenius Water Innovation AB reserve the right to make changes to components, specifications and modify the contents of the documentation without further notice.

Wallenius Water Innovation AB only guarantees correct function of the unit with original or specified components.

The FluidWorker 100 is intended for use of process fluid treatment only. Any other use is prohibited.

1.2 Warranty

Wallenius Water Innovation AB warrants that this product will be free from defects in material and workmanship for a period of one year from the date of delivery.

Within the warranty period Wallenius Water Innovation AB will repair or replace such products and component parts which are returned to Wallenius Water Innovation AB with shipping charges prepaid and which are determined by Wallenius Water Innovation AB to be defective.

This warranty will not apply to any product or component part which has been subjected to misuse, negligence or accident; or misapplied; or modified or repaired by unauthorized persons or not installed according to specification given in this manual.

Any attempt to change or modify existing equipment with non-original components invalidates the warranty.

Consumable products (UV lamp and quartz sleeve) have a warranty period of 3 months from delivery date.

Buyer shall inspect the product promptly after receipt and shall notify Wallenius Water Innovation head office in writing of claims, including claims of breach of warranty, within thirty days after the buyer discovers or should have discovered the facts upon which the claim is based.

Failure of the buyer to give written notice of a claim within the time period shall be deemed to be a waiver of such claim.

1.3 Manufacturer

Wallenius Water Innovation AB

www.walleniuswater.com

1.4 Service and support

For any support issues, please contact Wallenius Water Innovation AB through:

e-mail: support@walleniuswater.com

telephone: +46 8 120 138 10 during office hours

fax: +46 8 522 722 99

1.5 Disposal

Always consult local rules and regulations for correct handling of each material:

- Used UV lamps can be handled and recycled in the same way as fluorescent lamps.
- Used quartz sleeves can be recycled in the same way as recyclable glass.

At end-of-life, the FluidWorker 100 must be disposed of according to local rules and regulations.

1.6 Validation

This installation and operation manual applies to FluidWorker 100.

1.7 Acronyms and abbreviations

LPS

Lamp Power Supply

HMI

Human Machine Interface.

This is the operation control, the touch display placed on top of the FluidWorker 100.

2 Safety

2.1 Warning, caution, and notes

WARNING	Indicates a potentially hazardous situation which could result in death or severe injury.
CAUTION	Indicates a potentially hazardous situation which could result in property damage.
NOTE	A note is used to notify people of installation, operation or maintenance information which is important but not hazard related.

2.2 General safety rules

This chapter contains the safety instructions which you must follow when installing, operating and servicing the system. If ignored, physical injury or death may follow, or damage may occur to the drive, the motor or driven equipment.

WARNING	UV-radiation can instantly harm eyes and skin, never look into a burning lamp! Always use necessary protective equipment (such as protective glasses and gloves) when working with the UV lamps.
WARNING	Do not operate the FluidWorker 100 in explosive environments.
CAUTION	This equipment must be installed by authorized installation technicians and the installation must adhere to applicable local rules and regulations as well as these installation instructions.
CAUTION	Make sure the installation conditions meets the technical specification described in this manual (for example, electrical input).
CAUTION	The FluidWorker 100 must be mounted on a rigid and

	solid surface.
CAUTION	Never use the cords for carrying or pulling the FluidWorker 100.
CAUTION	Lifting the FluidWorker 100 requires two people. The system weighs 63 kg.
CAUTION	Do not operate the FluidWorker 100 without process fluid in the system.
CAUTION	UV lamp and quartz sleeve are fragile components, please handle these components with care.

3 Transportation

The FluidWorker 100 is transported on a half euro pallet.
When the FluidWorker 100 is shipped, it comes in one unit.

3.1 Unpacking

CAUTION

Lifting the FluidWorker 100 requires two people. The system weighs 110 kg including pallet and pallet collar.

Check that there are no transportation damages.

3.2 Delivery inspection

CAUTION

**Do not touch the new lamp or sleeve with bare hands.
Use protective gloves!
Fingerprints on the lamp may impair the intensity of the light.**

Check the FluidWorker 100 in general for any damages. Especially check the UV lamp and quartz sleeve for damages.

Use the packing list and tick off accordingly.

If something is missing or if any part of the FluidWorker 100, the UV lamp or the quartz sleeve are damaged - contact your distributor.

Notify Wallenius Water Innovation office immediately if damages are found.

3.3 Inspection of UV lamp and quartz sleeve

To inspect the UV lamp and quartz sleeve, do the following:

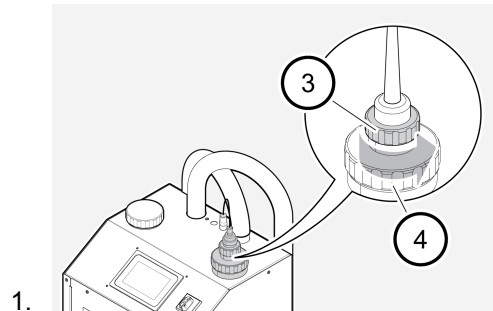

Disconnect the lamp from the power supply by removing the lamp lock nut (3) from the quartz sleeve lock nut (4).

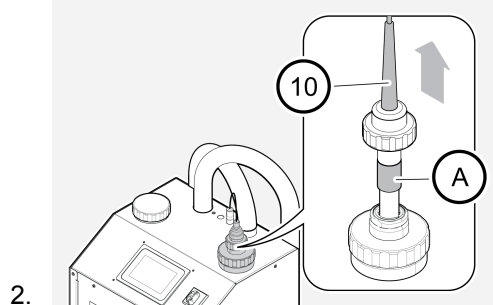

Pull out the lamp until the lamp socket (A) is visible. Carefully secure the lamp socket by a light grip during disconnection.

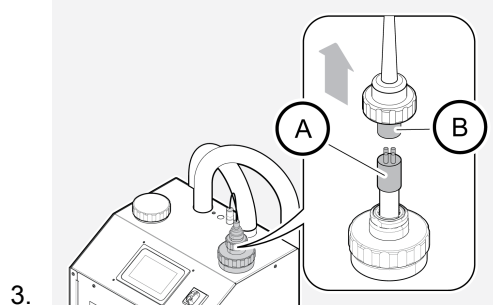

Hold the lamp firmly by the lamp socket (B) and disconnect it from the lamp (A).

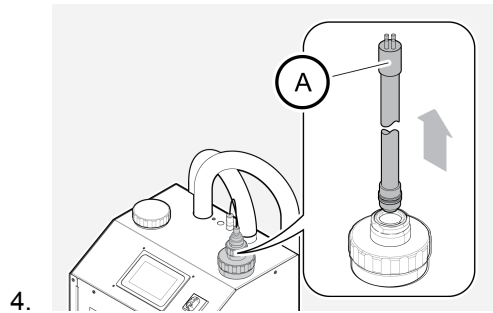

4. Carefully pull out the lamp (A) from the quartz sleeve.

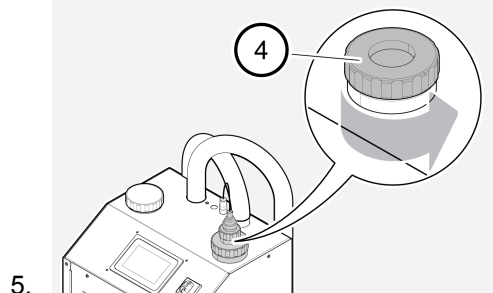

5. Unscrew the quartz sleeve lock nut (4) from the reactor.

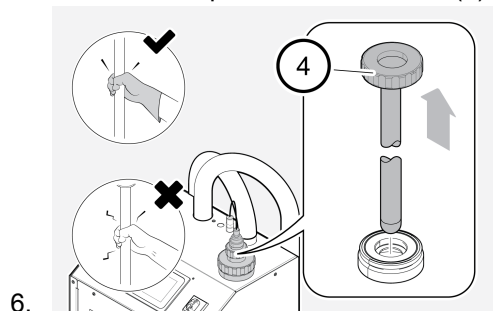

6. Gently lift the quartz sleeve and holder assembly from the reactor straight up until the full length of the quartz sleeve is outside the reactor
7. Visually inspect the UV lamp or the quartz sleeve for any transport damages.
8. Reassemble the unit by following the steps 1 to 5 in opposite order.

4 System Description

4.1 Functional description

FluidWorker 100 is based on a fluid purification technology that imitates nature's own way of degrading microorganisms. When the process fluid passes FluidWorker 100, it is irradiated with UV-C. The light inactivates the bacteria's DNA and makes the bacteria unable to reproduce.

FluidWorker 100 is a stand-alone purifier product that includes a reactor, a pump and a control system.

4.2 Control system

The control system monitor correct operation and trigger alarm at any operational fault. The FluidWorker 100 is managed through a 5" colour touch screen.

For more information regarding the control system, see Appendix - "Automatic control system" on page 53.

4.3 System overview

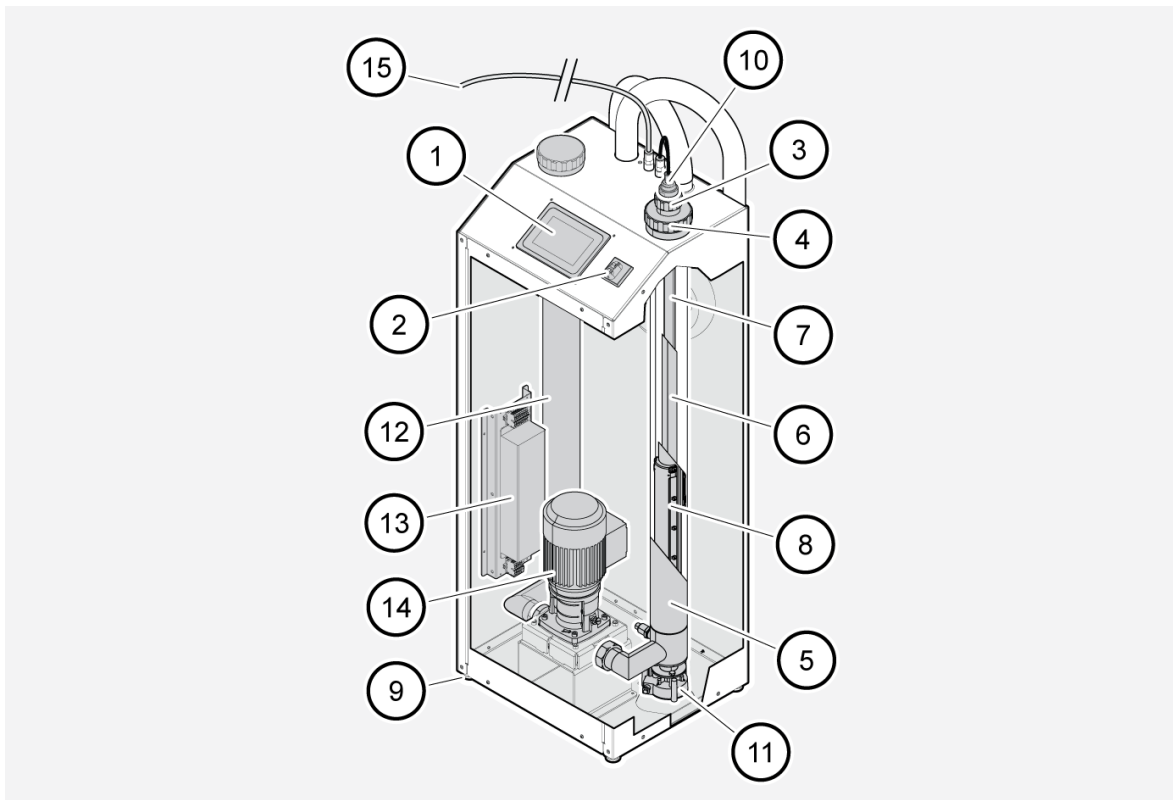

Position	Description	Position	Description
1	Touch display. 5" colour touch screen (HMI)	9	Cabinet
2	Main switch. The main power switch for the FluidWorker 100	10	Lamp power cable
3	Lamp lock nut	11	Motor for the FluidWorker 100 cleaning system (wiper)
4	Quartz sleeve lock nut	12	Priming tank
5	Reactor	13	Lamp power supply (LPS)
6	Quartz sleeve	14	Pump
7	UV lamp	15	Power cord. Mains 230VAC
8	Cleaning system (wiper)		

5 Installation

The installation process for the FluidWorker 100 is divided into these steps:

- Before installation
- Mechanical installation
- Electrical installation

5.1 Before installation

CAUTION

Read "Specifications" on page 44 carefully before installation.

- Make sure the general safety rules are applied. See "Safety" on page 3 - General safety rules.
- Thoroughly clean the system, in which the FluidWorker 100 will be installed, to get the best result.
- Make sure that there is enough room for service and maintenance:
 - Ceiling height minimum 2.4 m.

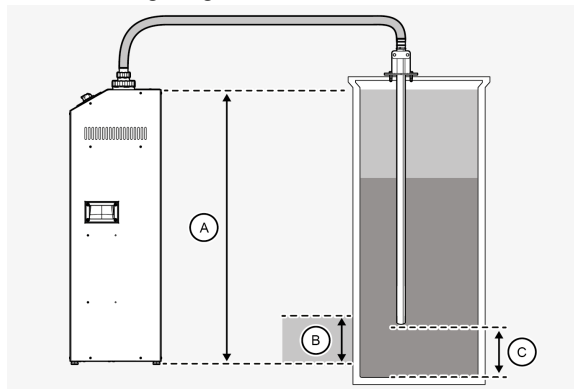

- Fluid surface must always be kept at a minimum of 200 mm (B) up to 1100 mm (A) measured from machine base.
- The inlet pipe must be kept at a minimum of 200 mm (C) from the fluid tank bottom.
- Place the FluidWorker 100 on a flat surface.
- The FluidWorker 100 is designed for permanent installation. Place the FluidWorker 100 close to the tank. Make sure that the hoses are fixed and secured to avoid interference with the surrounding work area or equipment.

5.2 Tools and materials

Description	Note
Wrench	10 mm for tank bracket.
Socket bit	10 mm for tank socket.
Allen key	5 mm for hose clamp.

Description	Note
Torx key	T20 for removal of back and front cover.
Philips Pozidrive	PH2 for feet adjustment.

5.3 Connecting the FluidWorker 100

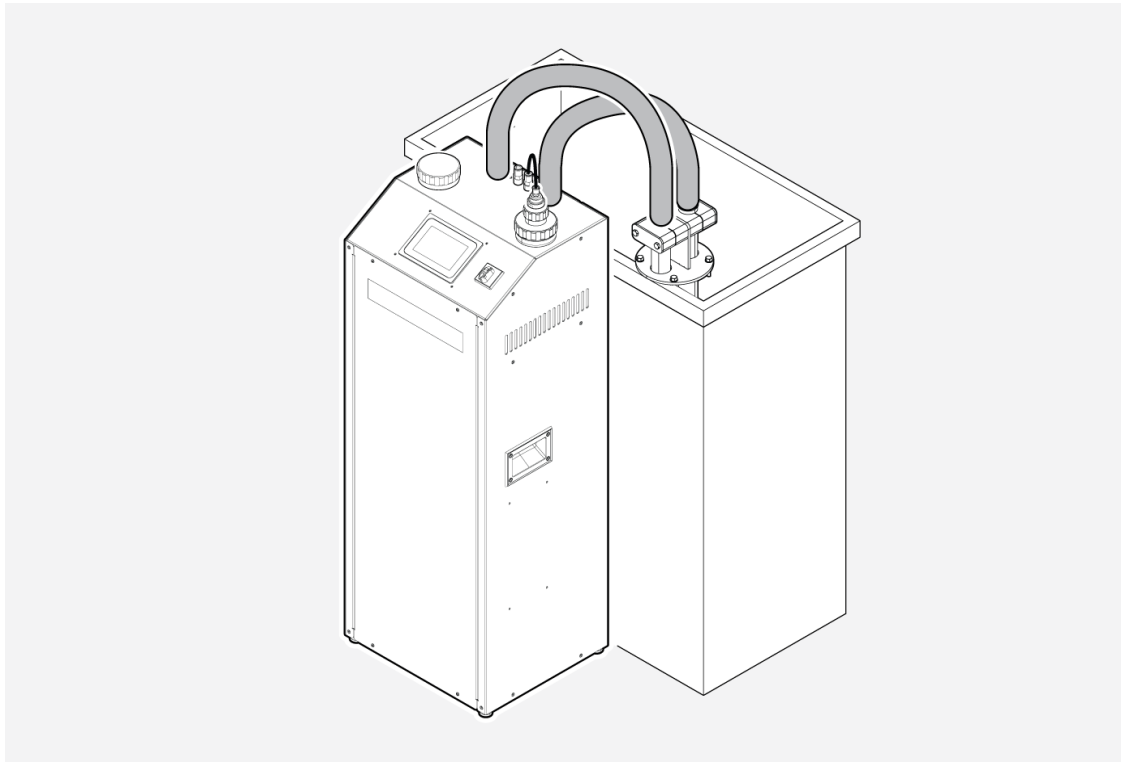

5.3.1 Connect to a process fluid tank

Depending on the type of tank, with or without tank top, select and perform one of the following procedures:

- Install on tank top or tank cover plate (Recommended).
- Install inside of tank wall.

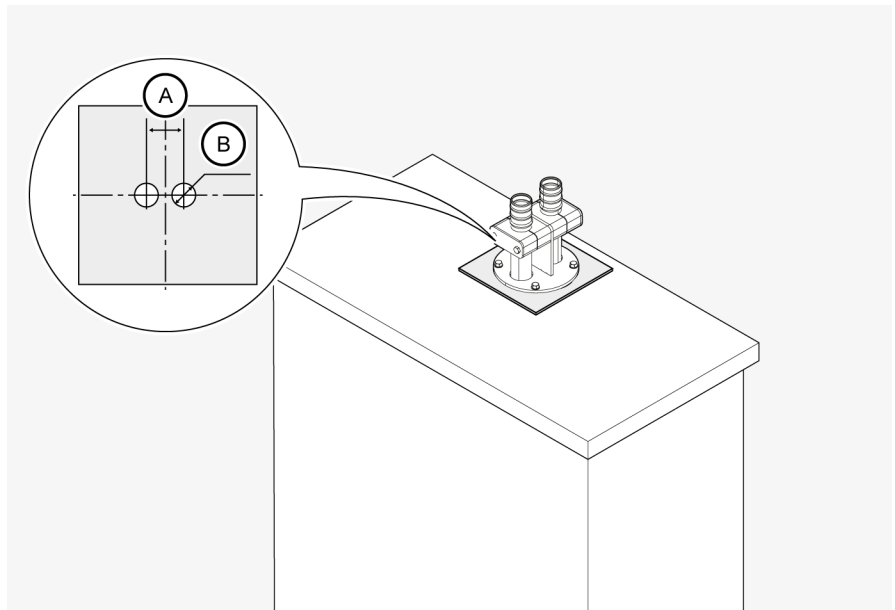
5.3.1.1 Install on tank top or tank cover plate (Recommended).

1. Loosen the cover from the tank and modify two holes, where the distance (A) is 63 mm and the diameter (B) is 40 mm. If no cover plate is present the holes are made directly on the tank top.
2. Loosen the clamping jaw on the straight pipe (inlet) and move it upwards.
3. Assemble both inlet and outlet pipes through the holes in the tank cover.
4. Lower the inlet pipe and tighten the clamping jaw.
5. Use the supplied self-tapping screws to attach the tank bracket assembly to the tank cover.
6. Measure the process fluid tank depth. Loosen the two screws on the clamping jaw slightly and adjust so that the ends of the pipes are approximately 200 mm from the tank bottom.

5.3.1.2 Install inside of tank wall

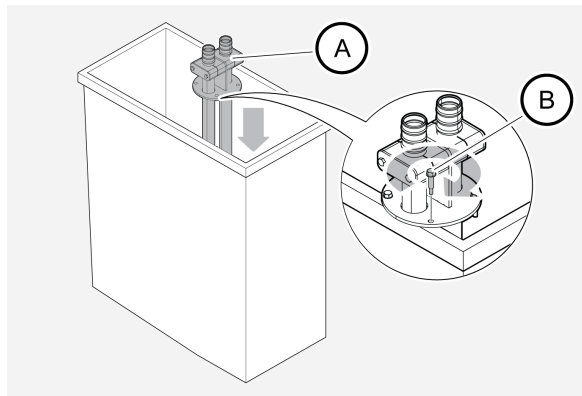

1.

Install the tank bracket (A) on the inside of the process fluid tank. Use the supplied self-tapping screws (B). Adjust the screws (B) to support the bracket against the tank wall. Make sure all the screws are tightly fitted.

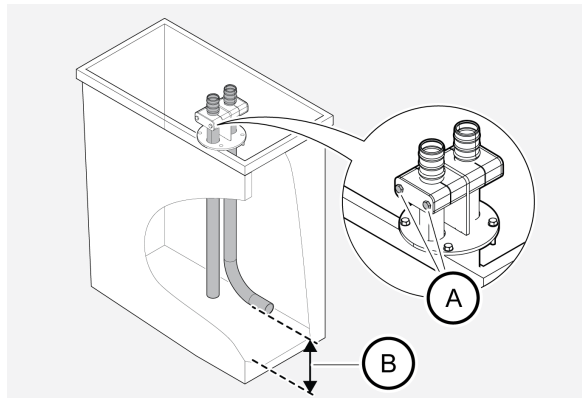

2.

Measure the process fluid tank depth. Loosen the two screws (A) on the clamping jaw slightly and adjust so that the ends of the pipes are approximately 200 mm (B) from the tank bottom.

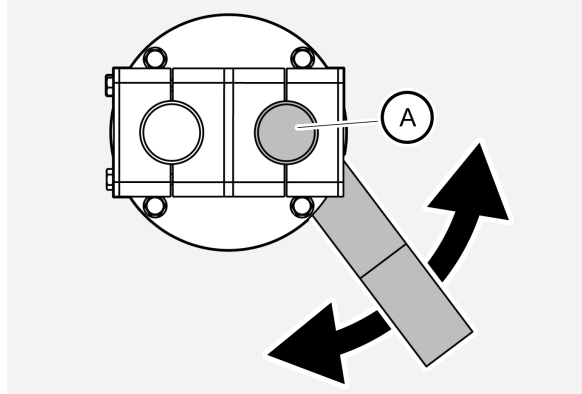

3.

Adjust the angle of the outlet pipe to create a good circulation in

the tank. The circulation is needed to avoid short-circuiting of the flow between the inlet and outlet pipe.

4. Tighten the screws on the clamping jaw.

5.3.2 Connecting the hose to the inlet and outlet pipes

NOTE

Make sure that the FluidWorker 100 is placed so that the hoses will not get entangled in machinery, equipment or people.

NOTE

Note the arrows on hoses and connection pipes to ensure correct direction of flow.

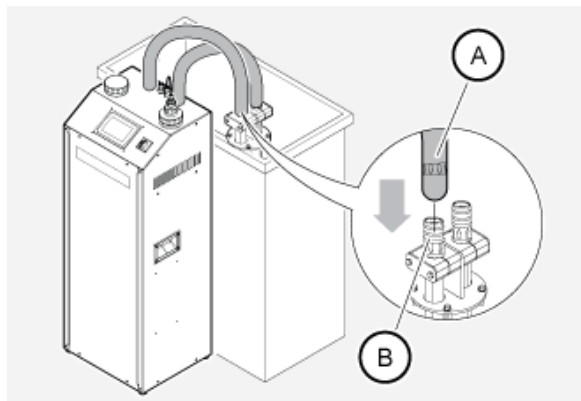

1. Fasten the hoses (A) to the inlet and outlet pipes (B) using the included pipe clamps and ensure that there is no leakage.

5.3.3 Priming the system

In order to secure that the pump does not run dry, the FluidWorker 100 must be primed before the system is taken in use.

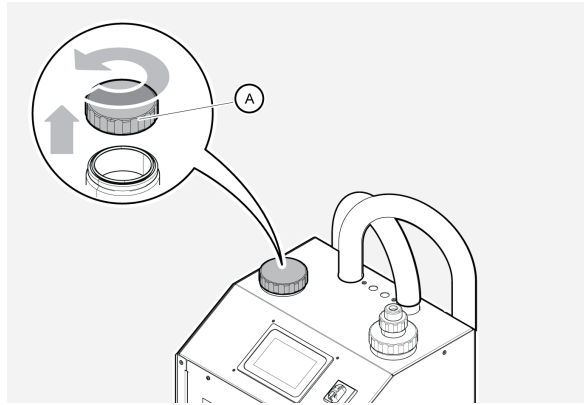

1. Unscrew and remove the lid (A) on the top of the priming tank.
2. Fill the tank with process fluid or water.
3. Screw the lid back on. Make sure the lid is tightly fastened.

NOTE

Push the stop button to cancel the priming procedure.

5.4 Electrical installation

Before connecting the FluidWorker 100 to main power, consider the following:

- The system requires a 10 A main fuse.
- The system consumes 2 A, maximum.
- The system is of the overvoltage category type II.

1. Connect the main power plug to the mains.

The installation is now finished. Go to "Operation" on page 18 and start to learn about how to use the FluidWorker 100.

6 Operation

6.1 Important information

WARNING

Risk of exposure to UVC rays. UVC rays are harmful to the eyes and the skin, never look into a lit lamp! Always use necessary protective equipment (such as protective glasses and gloves) when working with the quartz sleeve and UV lamp.

CAUTION

Never operate the FluidWorker 100 without process fluid or water in it!

CAUTION

The water in the FluidWorker 100 must not freeze. Always drain the FluidWorker 100 before storage, transportation or when it is not in use.

If the FluidWorker 100 or system which it is installed to are left unused for long periods of time (several weeks), cleaning of the entire system might be required.

The lamp power supply used in FluidWorker 100 is specifically validated to operate with the UV lamp provided with the unit. Using non-original components can damage the unit and the surrounding equipment. Any attempt to change or modify existing equipment with non-original components invalidates the warranty.

The FluidWorker 100 can be operated in Intermittent mode in order to spare the lamp. See Appendix "Intermittent operation" on page 63

6.2 Starting up

NOTE

Make sure the FluidWorker 100 is primed before start. If not, go to "Priming the system" on page 15.

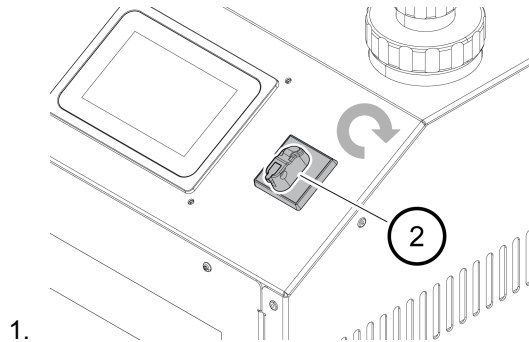

1. Turn on the main switch (2).

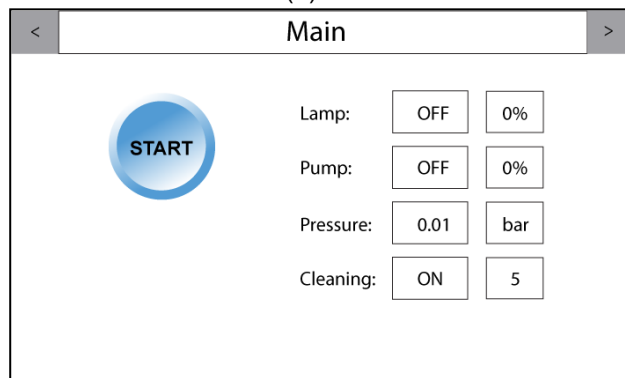

2. Press the *START* button on the touch display. The pump starts and the system is running after a few seconds. If the system does not start, go to "Troubleshooting" on page 41.

For 30-60s after start the machine will perform a priming cycle. After the priming cycle the machine will continue with normal operation.

6.3 Turning off

NOTE

The clock symbol is only visible when lamp power setting is 70% or less.
When lamp power is set to 80% or greater the clock symbol is hidden.

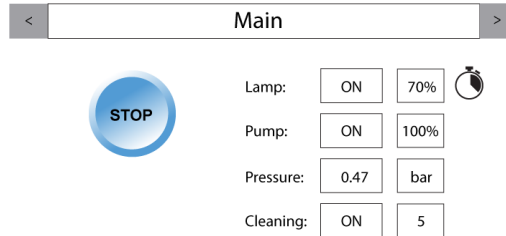

1. Press the *STOP* button on the touch display, the system will stop after a few seconds.

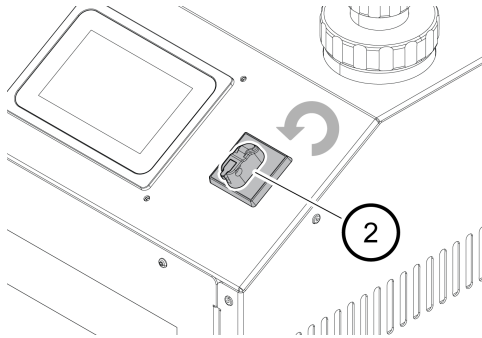

2. Turn the main switch (2) to off.

7 Service and Maintenance

WARNING

Risk of exposure to UVC rays. UVC rays are harmful to the eyes and the skin, never look into a burning lamp! Always use necessary protective equipment (such as protective glasses and gloves) when working with the quartz sleeve and the UV lamp.

WARNING

The unit operates with electrical power. Electrical power can cause electrical shocks. Disconnect power before service and use a residual current device, RCD.

CAUTION

Do not touch the quartz sleeve with bare hands. Use protective gloves! Fingerprints may impair the intensity of the light.

NOTE

Wallenius Water Innovation AB only guarantees correct function of the unit with original or specified components.

The FluidWorker 100 utilizes an ultraviolet lamp encased in a quartz sleeve to separate the fluid from direct contact with the lamp itself.

7.1 Lamp replacement

WARNING

Wait approximately 10 minutes, after the power is turned off, before working on the FluidWorker 100 in order to let it cool off.

7.1.1 Service interval

For recommended service intervals, see "Spare parts" on page 43

7.1.2 Tools and materials

Description	Note
Protective gloves	Use clean protective gloves

7.1.3 Procedure

CAUTION

Do not use tools when replacing the lamp. The lamp is very sensitive to any form of contamination. Always use clean protective gloves when touching the lamp.

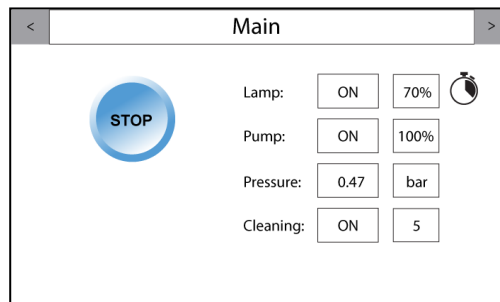

1.

Press the *STOP* button on the touch display, the system will stop after a few seconds.

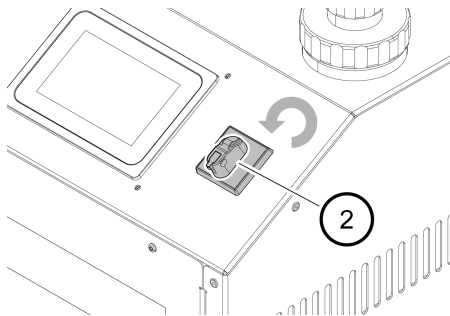

2.

Turn off the main switch (2) and wait ten minutes.

3. Disconnect the main power plug from the mains.

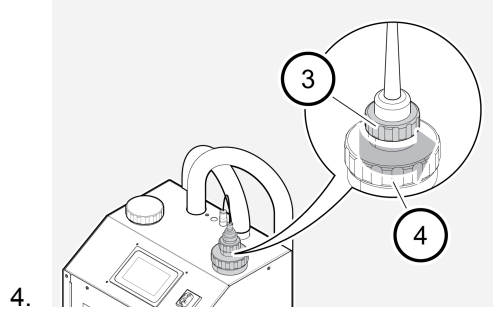

4. Disconnect the lamp from the power supply by removing the lamp lock nut (3) from the quartz sleeve lock nut (4).

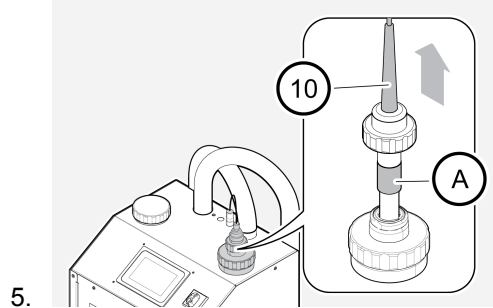

5. Pull out the lamp until the lamp socket (A) is visible. Carefully secure the lamp socket by a light grip during disconnection.

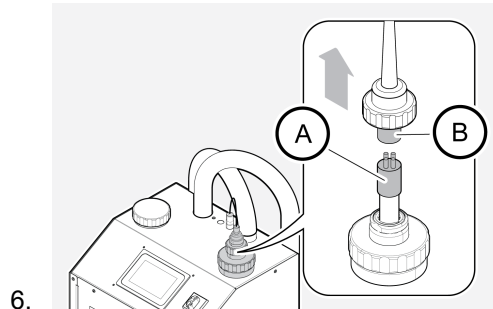

6. Hold the lamp firmly by the lamp socket (B) and disconnect it from the lamp (A).

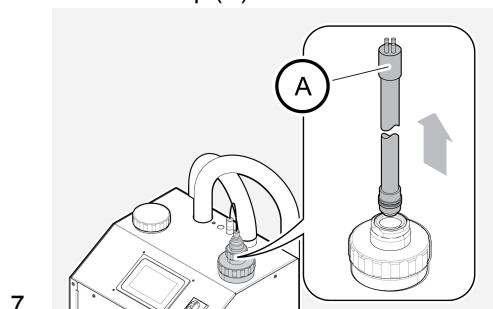

7. Carefully pull out the lamp (A) from the quartz sleeve. Recycle the parts.

8. To mount the new lamp, follow the steps 2 to 6 in reverse order.
9. Connect the main power plug to the mains.
10. Start up the system, see "Starting up" on page 19.
11. Reset the lamp timer.
12. Make a note in the "Maintenance Record" on page 67 that the lamp has been replaced.

7.2 Quartz sleeve replacement

WARNING

Wait approximately 10 minutes, after the power is turned off, before working on the FluidWorker 100 in order to let it cool off.

7.2.1 Service interval

For recommended service intervals, see "Spare parts" on page 43

7.2.2 Tools and materials

Description	Note
Protective gloves	Use clean protective gloves

7.2.3 Procedure

CAUTION

Do not use tools when replacing the sleeve. The lamp is very sensitive to any form of contamination. Always use clean protective gloves when touching the sleeve.

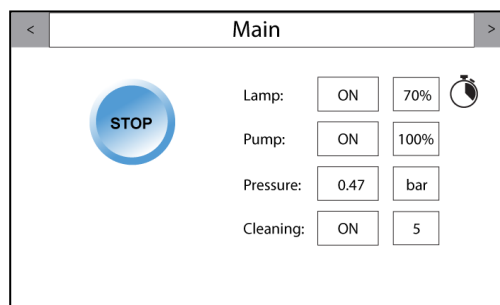

1. Press the *STOP* button on the touch display, the system will stop after a few seconds.

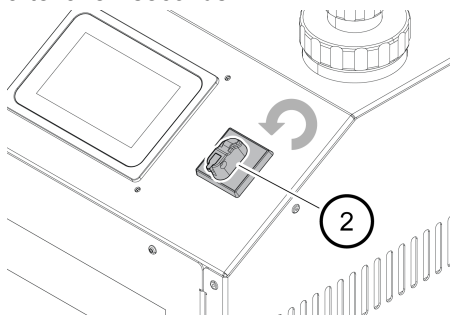

2. Turn off the main switch (2) and wait ten minutes.

3. Disconnect the main power plug from the mains.

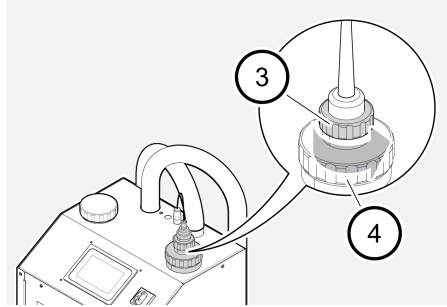

4. Disconnect the lamp from the power supply by removing the lamp lock nut (3) from the quartz sleeve lock nut (4).

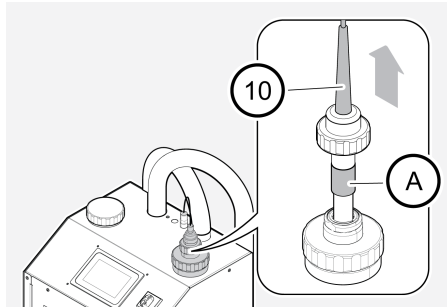

5. Pull out the lamp until the lamp socket (A) is visible. Carefully secure the lamp socket by a light grip during disconnection.

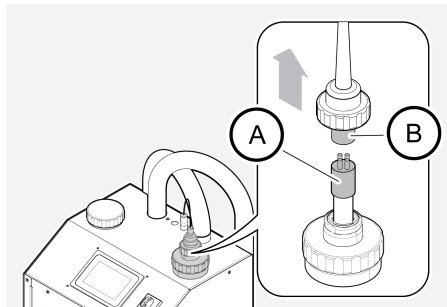

6. Hold the lamp firmly by the lamp socket (B) and disconnect it from the lamp (A).

CAUTION

Take care not to touch the lamp with bare hands. Always use clean protective gloves when touching the lamp.

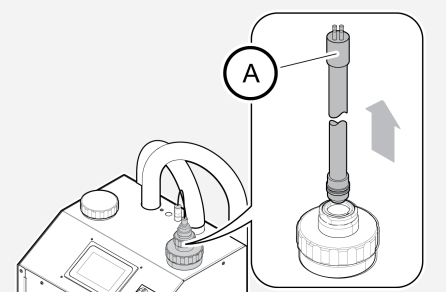
7.  Carefully pull out the lamp (A) from the quartz sleeve using the lamp top.
8. Place the lamp in a protected environment.

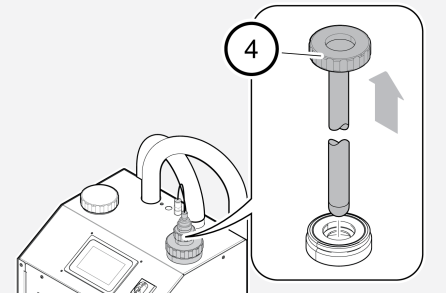
9.  Unscrew the quartz sleeve lock nut (4) from the reactor. Gently lift the quartz sleeve and holder assembly from the reactor straight up until the full length of the quartz sleeve is outside the reactor.
10. Recycle the parts, see "Disposal" on page 2.
11. Install the quartz sleeve and lamp by following step 3 to 8 above in opposite order. To avoid unnecessary leakage, lower the quartz sleeve the last bit slowly and gently.
12. Wipe away any fluid around the quartz sleeve holder with a cloth.

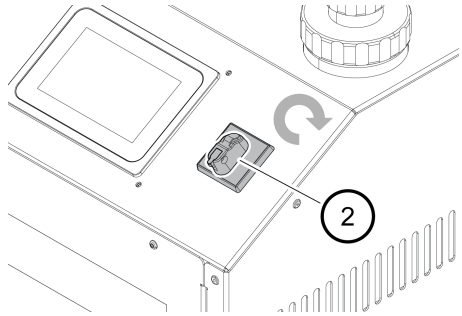
13.  Turn on the main switch (2).
14. Connect the main power plug to the mains.

15. Start up the system, see "Starting up" on page 19.
16. Reset the clean interval timer on the maintenance screen. For more information, see Appendix - Automatic control system - "Maintenance" on page 60.
17. Make a note in the Appendix - "Maintenance Record" on page 67 that the quartz sleeves have been replaced.

7.3 Strainer Inspection

WARNING

Wait approximately 10 minutes, after the power is turned off, before working on the FluidWorker 100 in order to let it cool off.

7.3.1 Service interval

For recommended service intervals, see "Spare parts" on page 43

7.3.2 Tools and materials

Description	Note
Brush	Use a clean brush
Protective gloves	Use clean protective gloves

7.3.3 Procedure

The strainer needs regular cleaning depending on the amount of particles in the fluid. Cleaning must be done on a regular basis. A general indication to clean the strainer is when system pressure has dropped 0.1 bar from the pressure of a clean system (measured at 100% pump setting).

NOTE

Running the FluidWorker 100 with an obstructed strainer (>0.1 bar pressure drop) will cause poor system performance.

A fully obstructed strainer will trigger the system low pressure alarm and shut down the machine.

To clean the strainer, do the following:

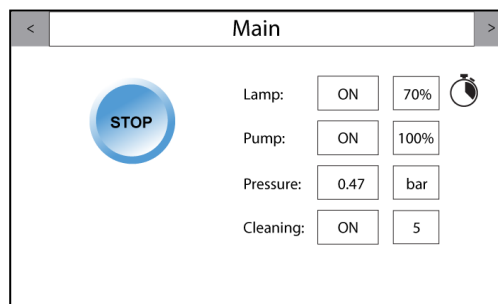

1.

Press the *STOP* button on the touch display, the system will stop after a few seconds.

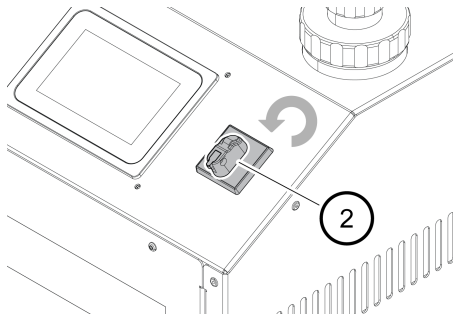

2. Turn off the main switch (2).
3. Disconnect the main power plug from the mains.

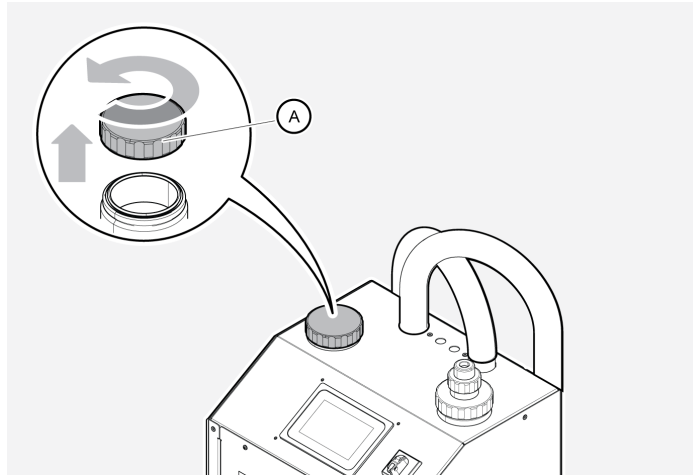

4. Unscrew and remove the lid (A) on top of the priming tank.

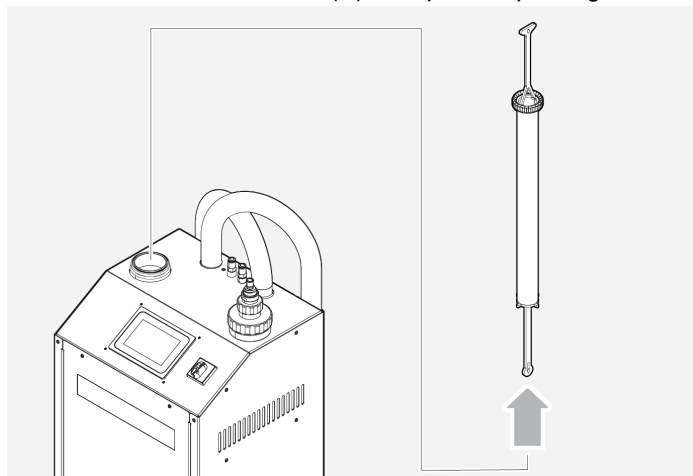

5. Gently lift the strainer from the priming tank.

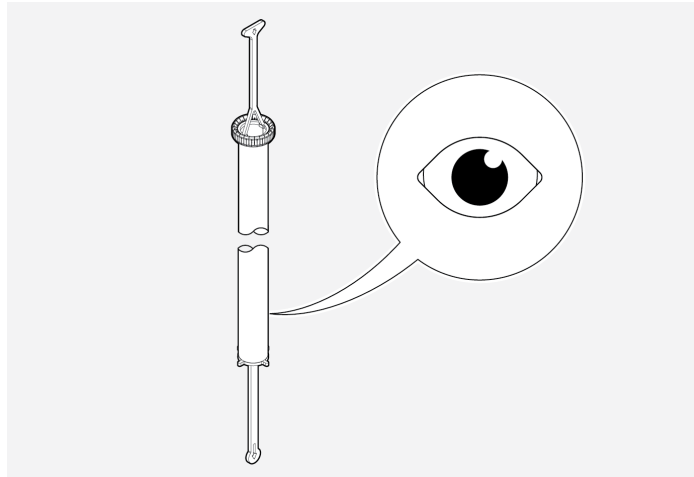

6.

Inspect the strainer to ensure that it is clean.

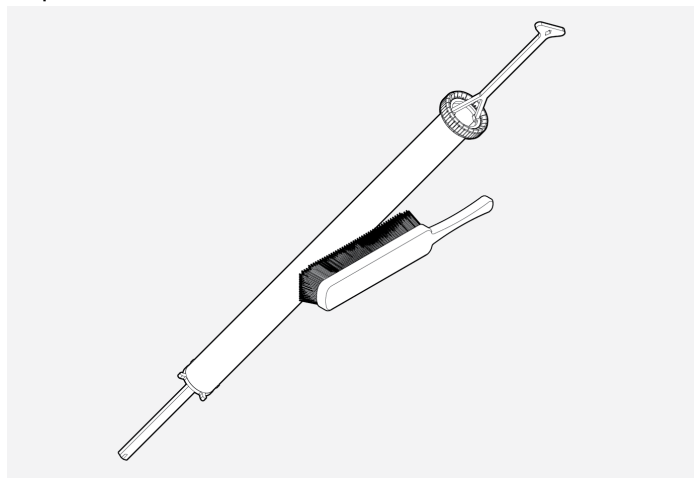

7.

If necessary, use a brush and water at 40 °C to clean the strainer.

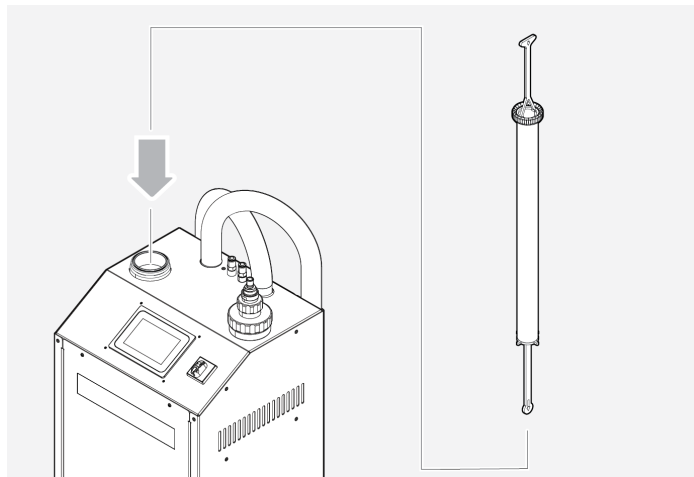

8.

Gently re-insert the strainer into the priming tank.

9. Prime the tank, see "Priming the system" on page 15

10. Wipe away any fluid around the priming lid with a cloth.
11. Connect the main power plug to the mains.
12. Start up the system, see "Starting up" on page 19

7.4 Replacement of cleaning system components

WARNING

Wait approximately 10 minutes, after the power is turned off, before working on the FluidWorker 100 in order to let it cool off.

To secure optimal function of the cleaning system, the cleaning system components are subject for replacement after one year of operation.

The replacement can be done in one of the following ways:

- a. Replacement of a complete inner reactor, skip steps 4-7 in the procedure.
- b. Replacement of individual wiper cassettes (2 pcs).

7.4.1 Service interval

For recommended service intervals, see "Spare parts" on page 43

7.4.2 Tools and materials

Description	Note
Torx key	T20 to remove the front cover and to disassemble wiper cassettes.

7.4.3 Procedure

1. Follow steps 1 through 9, of the instructions in "Quartz sleeve replacement" on page 25.

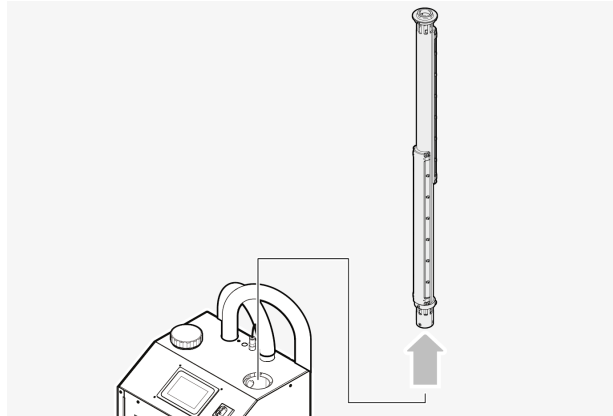

2. Gently lift the cleaning system from the reactor.
3. Allow a few seconds to let the cleaning system drain completely inside reactor before it is removed.

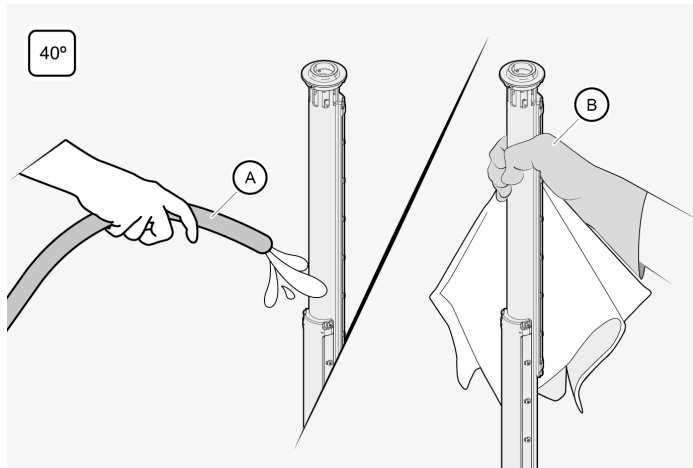

4. Rinse the cleaning system with 40 °C water to remove dirt and oil. Wipe dry with a cloth.

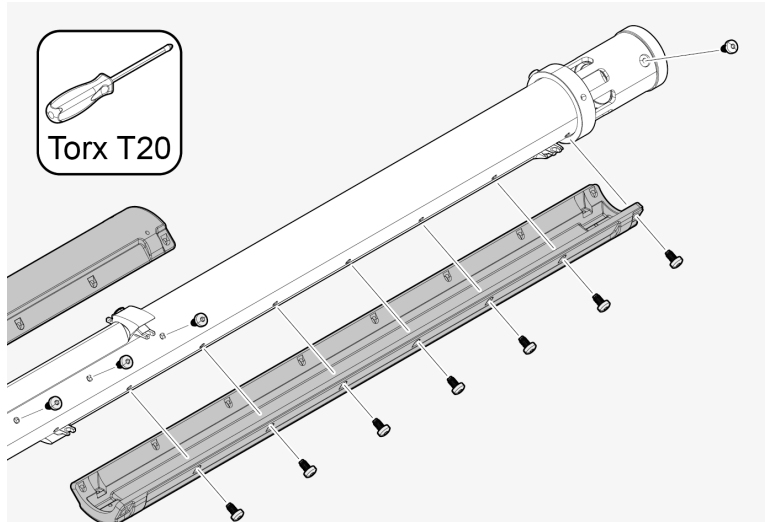

5. Disassemble both wiper cassettes with a Torx (T20) screwdriver.

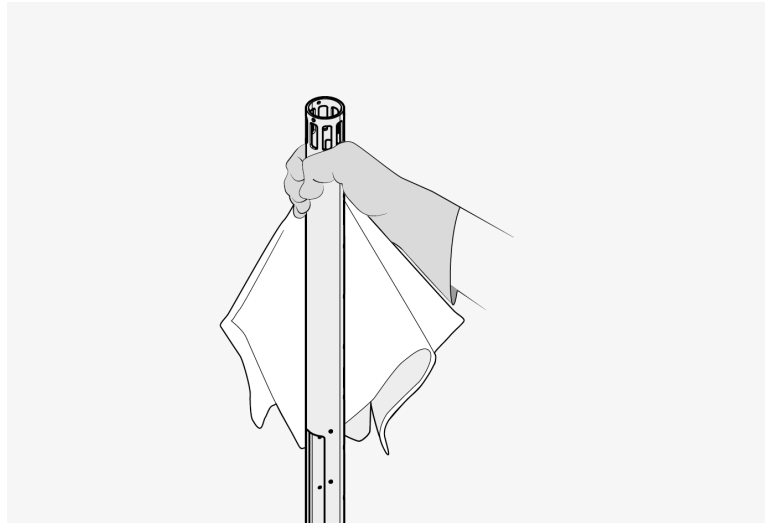

6. Wipe the pipe clean with a cloth.

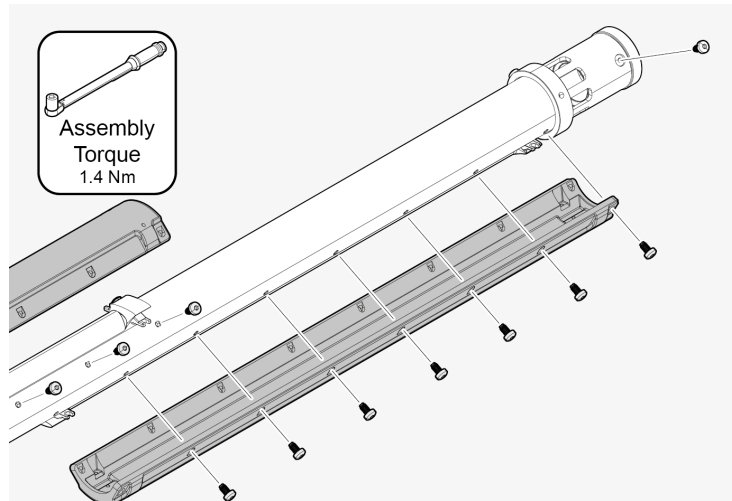

7.

Replace wiper cassettes. Use assembly torque of 1.4 Nm.
Do NOT use electric screwdriver.

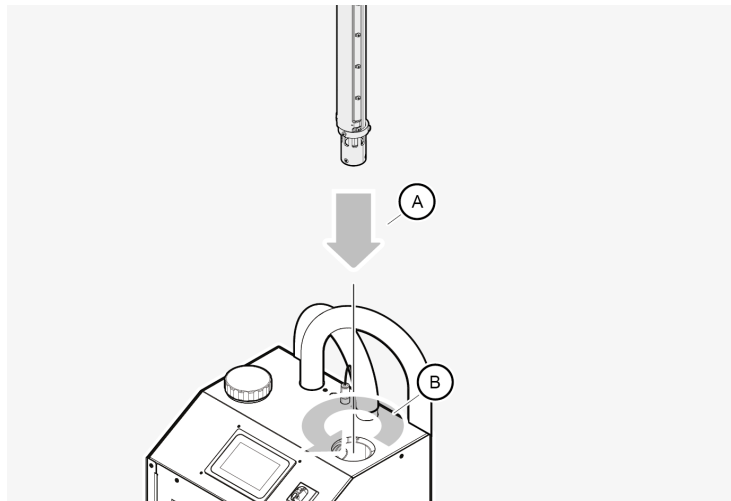

8.

Install the cleaning system straight down into the reactor (A).

9. Rotate unit (B) until the drive pins engage to drive coupling in the bottom of the reactor.
10. Re-assemble quartz sleeve and UV lamp as described in steps 10 through 16 of the instructions in "Quartz sleeve replacement" on page 25.

7.5 Software/Firmware upgrade

If the software or firmware is subject for upgrade, you will receive an e-mail with the upgrade enclosed.

Prerequisites:

- Formatted (FAT32) and empty USB stick (min 512 MB)

7.5.1 Tools and materials

Description	Note
Torx key	T20 to remove the front cover.

7.5.2 Procedure

1. Put the upgrade file, into a folder called "firmware", onto the USB-stick.

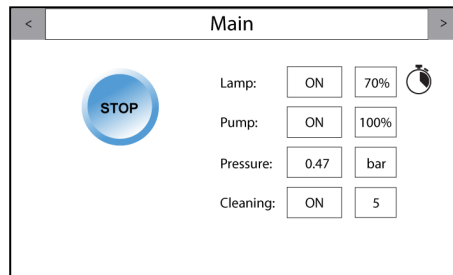

2. Press *STOP* to switch off the FluidWorker 100.

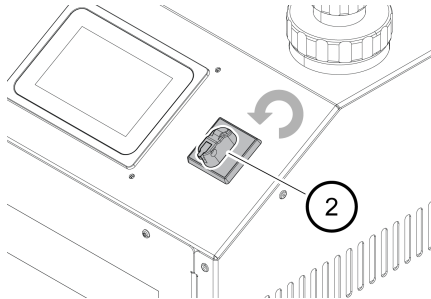

3. Turn off the main switch (2).
4. Disconnect the mains plug.

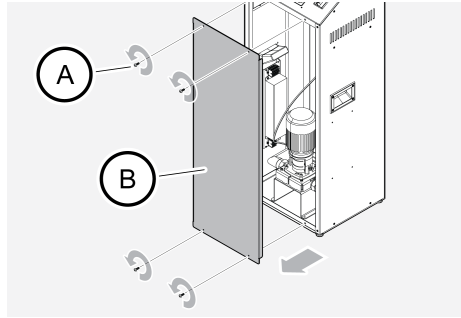

5. Remove four screws (A) to remove the front cover (B).

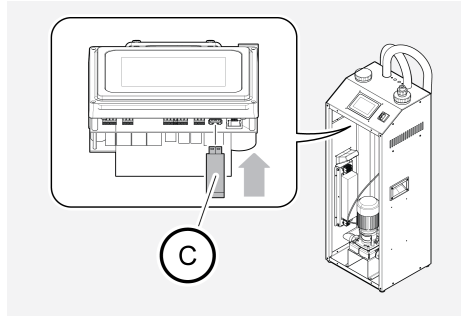

6. Insert the USB-stick into the USB port (C).

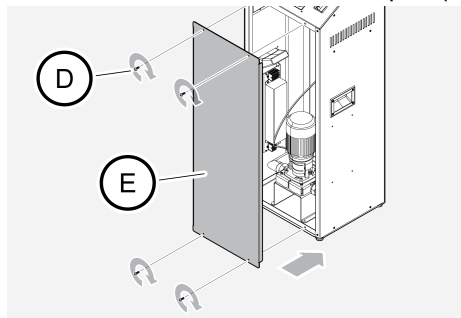

7. Mount the cover (E) and fasten the front cover using the four screws (D).
8. Connect the mains plug.

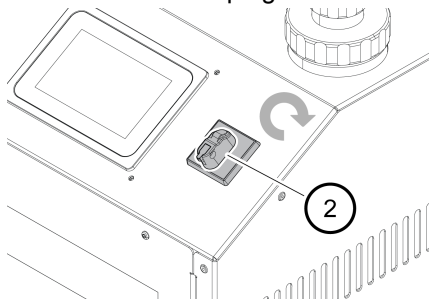

9. Turn on the main switch (2)
The system will automatically upgrade.
10. Wait until the system is upgraded.
11. Turn off the main switch.

12. Disconnect the mains plug.

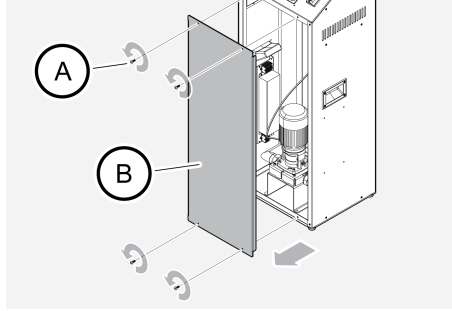

- 13.

Remove four screws (A) to remove the front cover (B).

14. Remove the USB-stick.

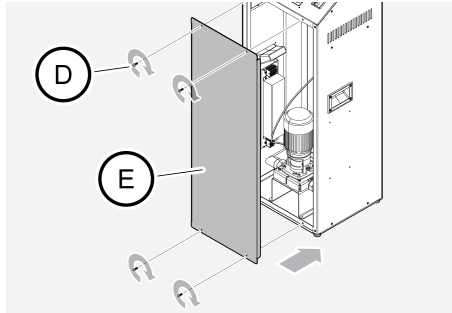

- 15.

Mount the cover (E) and fasten the front cover using the four screws (D).

16. Connect the mains plug.
17. Turn on the main switch.
18. Make a note in the "Maintenance Record" on page 67 that the system is upgraded and to which revision.

8 Uninstallation

1. Turn off the system
2. Loosen the brackets holding the inlet and outlet pipes on the process fluid tank.
3. Raise the pipes over the fluid surface and tighten the brackets.
4. Turn on the system for 30 seconds.
The action partly drains the system.
5. Turn off the system.
6. Unplug the mains plug.

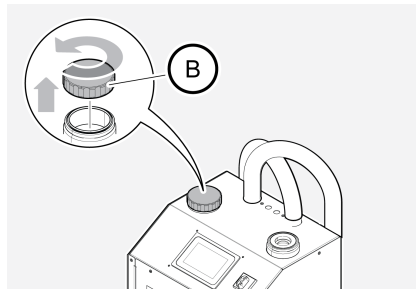

7. Remove the primer tank lid (B).
8. Drain the system using a wet vacuum in the priming tank, approximately 3 liters of fluid.
9. Remount the priming tank lid.
10. Remove the tank bracket from the process fluid tank.
11. Handle the drained process fluid according to local legislation and company rules.

9 Troubleshooting

9.1 Alarm list

NOTE

Hard alarms WILL shut down the FluidWorker 100.
Soft alarms will NOT shutdown the FluidWorker 100.

Soft alarms only informs that service is required.

9.2 Hard alarms

Hard Alarms	Event log	Probable cause
Pump Error	Pump Error	<ol style="list-style-type: none"> 1. Frequency converter PCB in FW100 do have too high temperature. (FW100 can be restarted after wait/cooled down time). 2. Pump is short-circuited. (FW100 cannot be restarted after wait/cooled down time).
Pump high current	Pump high current	<ol style="list-style-type: none"> 1. Pump wrongly connected (one phase is disconnected). 2. The pump is broken and needs to be replaced.
Pump low current	Pump low current	Pump not properly connected
Ballast error	Ballast error	<ol style="list-style-type: none"> 1. The ballast is not connected. 2. The ballast is broken and needs to be replaced.
Preheat error	Preheat error	One or more of the four wires between LPS and lamp is not connected and thereby preheat sequence is aborted
Lamp error	Lamp error	<ol style="list-style-type: none"> 1. The UV lamp is broken and needs to be replaced. 2. The ballast Indicator signal is not connected
External off activated	External off activated	External equipment has stopped the FW100 by short-circuited the terminals X11:1 and X11:2.

Hard Alarms	Event log	Probable cause
System low pressure	Normal operation: System low pressure At priming stage: Priming sequence failed (low pressure)	<ol style="list-style-type: none"> 1. The system has not been primed (dry running protection for the pump). 2. Inlet pipe blocked. 3. Strainer is clogged. 4. Strainer is dirty. 5. Pump broken or clogged. 6. Pump is running in the wrong direction. 7. Pressure sensor broken.
System high pressure	System high pressure	<ol style="list-style-type: none"> 1. The outlet pipe is blocked. 2. Pressure sensor broken.
Stopped due to mains voltage or switch	Stopped due to mains voltage or switch	<p>During machine operation the FW100 mains was disconnected:</p> <ol style="list-style-type: none"> 1. User turned off the unit using the units's power switch. 2. Mains failure on site (low voltage / spikes / power failure).
Wiper high current	Wiper high current	<ol style="list-style-type: none"> 1. The wiper motor is stucked. 2. The wiper motor is broken.

9.3 Soft alarms

Soft Alarms	Event log	Probable cause
Wiper low current	Wiper low current	<ol style="list-style-type: none"> 1. Wiper motor not connected. 2. Wiper motor broken.
Lamp life timer	Lamp life timer	Time to replace lamp
Pump maintenance timer	Pump maintenance timer	Time to inspect the pump
Sleeve inspection timer	Sleeve inspection timer	Time to inspect sleeve
System low flow	System low flow	<ol style="list-style-type: none"> 1. Strainer is dirty. 2. Pump impeller is dirty/clogged. 3. Fluid pipes are clogged.

10 Spare parts

All spare part orders must include the following information:

- the FluidWorker 100 serial number.
- the article number of the spare part if it is visible.
- the spare part description (name).
- ordered quantity.

The spare parts list below include the most commonly used and ordered items. For other parts, please contact your distributor.

Spare parts

Part number	Description	Recommended service interval
39-01-0119	Lamp power supply (LPS)	On request
39-01-0120	FluidWorker 100 UV lamp including o-rings	Max 9 000h
39-01-0121	Quartz sleeve including holder/o-rings	On request
39-01-0122	Inner reactor, complete	On request
39-01-0123	Wiper cassette (1pcs)	Yearly
39-01-0124	Wiper motor	On request
39-01-0125	Complete logic board including display	On request
39-01-0126	Shaft/impeller for pump	On request
39-01-0127	Kit, shaft seal with O-rings kit for pump	On request

11 Specifications

11.1 Technical specifications

SYSTEM	FluidWorker 100
Flow, adjustable	3.9 - 5.6 m ³ /h
Number of UV lamps	1
Lamp power, adjustable	168 - 202 W
Pump power, adjustable	85 - 280 W
Total power consumption	270 - 500 W
Product noise level	<70 dB(A)
Max ambient operating temperature	45 °C
Max fluid temperature	45 °C
Tank volume (system and fluid dependent)	0.5 - 1.5 m ³
Self priming pump	Yes
Lockable circuit breaker	Yes
Pressure sensor	Yes
Service timer	Yes
External on/off via external switch	No
External status check via web interface	No
Automatic cleaning system (wiper)	Yes
5" Touch screen display	Yes
Strainer	Yes
Weight	48 kg
Max distance between tank and product	1.2 m
Max height over sea level for the system	2000 m
Max humidity during operation, storage, and transportation.	85% (no condensation)

REACTOR		FluidWorker 100	
Material reactor		Stainless steel EN 1.4301	
Material inner reactor		Stainless steel EN 1.4301	
Strainer		Stainless steel EN 1.4301	
Material in- and outlet pipe		Stainless steel EN 1.4301	
Hose material inside		NBR (fuel grade)	
Sealing		Viton®	
Protection class		IP21	
Wiper holder		PA12	
Bearings		PE1000	
Pump impeller		PES/PP 30% GF	

CABINET PANEL		FluidWorker 100	
Chassis material		Painted steel (RAL7035)	
Protection class		IP21	
Power input		230V 1-phase, 50Hz	
HMI		5" Color touch screen	

11.2 Motor, pump, lamp, and pressure combinations

These values are only guidelines. The data is from a specific installation and can differ depending on the installation conditions.

Pump setting %	Lamp setting %	Flow (l/min)	Pump power (W)	Lamp power (W)	Pump pressure (bar)
100	100	94	280	202	0.48
90	90	86.1	220	192	0.41
80	80	75	180	187	0.35
70	70	63.4	140	177	0.27
-	60	-	-	175	-
-	50	-	-	168	-

11.3 Dimensions

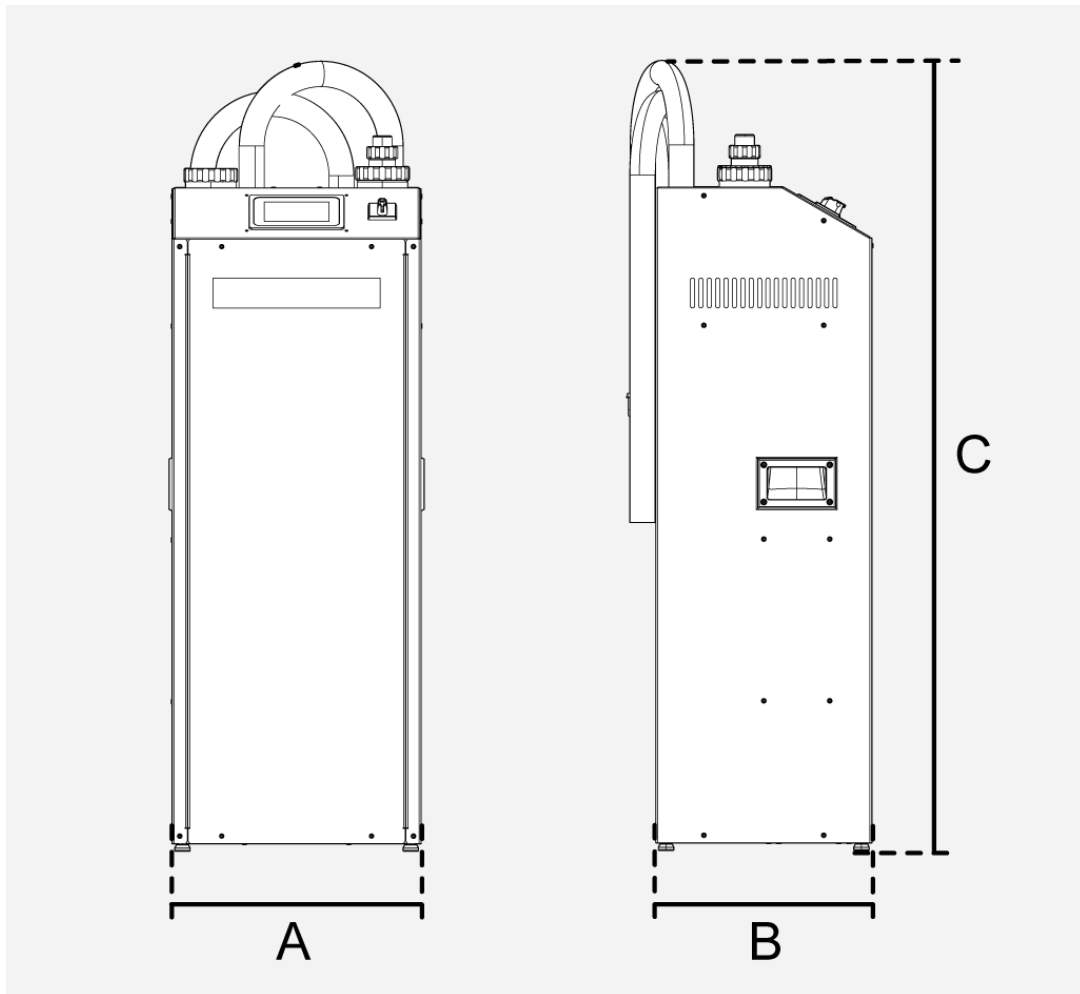

Dimension	Description	Value
A	Width	420 mm
B	Depth	360 mm
C	Height	1340 mm

A Appendix

A.1 Connection terminal list

X1 Wiper Motor

X1			
Pin	Name/Description	Type/Function	Comment
1	WIPER + (plus)	+24 VDC to Wiper for CW rotation.	Switched Transistor output (24 VDC / 0 VDC). Opposite voltage for CCW rotation
2	WIPER - (minus)	0 VDC to Wiper for CW rotation.	Switched Transistor output (24 VDC / 0 VDC). Opposite voltage for CCW rotation

X2 Power IN

X2			
Pin	Name/Description	Type/Function	Comment
1	L	Line	230VAC
2	N	Neutral	230VAC
3	PE	Protective Earth	Protective Earth

X3 Ballast power 2

X3			
Pin	Name/Description	Type/Function	Comment
1	L	Line	230VAC
2	N	Neutral	230VAC
3	PE	Protective Earth	Protective Earth

X4 Ballast power 1

X4			
Pin	Name/Description	Type/Function	Comment
1	L	Line	230VAC
2	N	Neutral	230VAC
3	PE	Protective Earth	Protective Earth

X5 Digital outputs hardware Terminal block

X5			
Pin	Name/Description	Type/Function	Comment
1	Relay1_CM	Common contact	Potential free relay contact SPDT 24-48VAC/2A
2	Relay1_NC	Normally closed contact	Potential free relay contact
3	Relay1_NO	Normally open contact	Potential free relay contact

X6 Digital outputs hardware Terminal block

X6			
Pin	Name/Description	Type/Function	Comment
1	Relay2_CM	Common contact	Potential free relay contact SPDT 24-48VAC/2A
2	Relay2_NC	Normally closed contact	Potential free relay contact
3	Relay2_NO	Normally open contact	Potential free relay contact

X7 Motor Power

X7			
Pin	Name/Description	Type/Function	Comment
1	Motor R	Motor power	230VAC
2	Motor S	Motor power	230VAC
3	Motor T	Motor power	230VAC
4	Motor Ground/PE	Protective Earth	Protective Earth

X8 Analogue inputs

X8			
Pin	Description	Type/Function	Comment
1	AI1_24VDC	+24V (Power)	Power to be used for analog input signals.
2	AI1_GND	0V/GND (Power)	General ground
3	AI1_Signal	Analog input signal. 0-10 VDC	Analog pressure sensor, 0-10 VDC / 0-7 bar.
4	AI1_shield	0V/GND (Power)	General ground
5	AI2_24VDC	+24V (Power)	Power to be used for analog/digital signals.
6	AI2_GND	0V/GND (Power)	General ground
7	AI2_Signal	Analog input signal. 0-10 VDC	Spare
8	AI2_shield	0V/GND (Power)	General ground

X9 Analogue outputs

X9			
Pin	Name/Description	Type/Function	Comment

X9			
1	AO1_Signal	Analog output (0-10VDC)	Ballast 0-10V
2	AO1_GND	Common ground	GND
3	AO2_Signal	Analog output (0-10VDC)	Spare
4	AO2_GND	Common ground	GND

X10 Digital Inputs 1

X10			
Pin	Name/Description	Type/Function	Comment
1	DI1_24VDC	+24VDC	Power to be used for digital input signals.
2	DI1_Signal	Transistor input (+24VDC)	Spare
3	DI2_24VDC	+24VDC	Power to be used for digital input signals.
4	DI2_Signal	Transistor input (+24VDC)	Spare
5	DI3_24VDC	+24VDC	Power to be used for digital input signals.
6	DI3_Signal	Transistor input (+24VDC)	Spare.
7	GND	GND to all inputs	GND

X11 Digital Inputs 2

X11			
Pin	Name/Description	Type/Function	Comment
1	DI4_24VDC	+24VDC	Power to be used for digital input signals

X11			
2	DI4_Signal	Transistor input (+24VDC)	Spare
3	DI5_24VDC	+24VDC	Power to be used for digital input signals
4	DI5_Signal	Transistor input (+24VDC)	Relay from Lamp power supply
5	DI6_24VDC	+24VDC	Power to be used for digital input signals
6	DI6_Signal	Transistor input (+24VDC)	Spare

X12 Modbus port-RS485

X12			
Pin	Name/Description	Type/Function	Comment
1	RS485_GND	GND	GND
2	RS485_B_-	RS485- (minus)	RS485 communication
3	RS485_A_+	RS485+ (plus)	RS485 communication

USB port

Ethernet port

A.2 Automatic control system

NOTE

Read this chapter carefully to learn about the screen control system.

This chapter gives a basic understanding of the functions in the screen based control system of the FluidWorker 100.

A.2.1 Screens – General functions

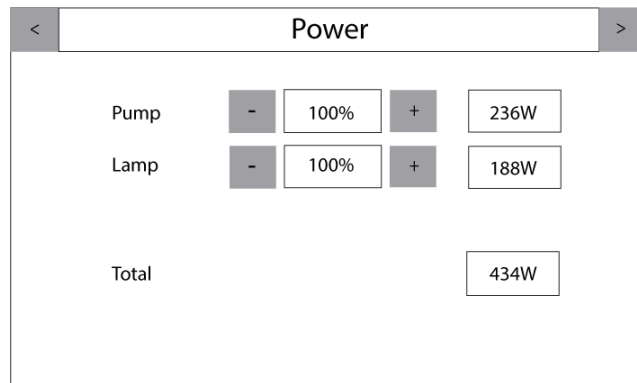

- Shows the title of the selected screen. This informs what function the screen has.
- Use the arrows to navigate through the screens.
- On some screens it is possible to alter the settings on different parameters. Use the - /+ buttons to reduce or increase the value.
- Shows the total power consumption of the unit.
- Shows the current power consumption of the lamp.

A.2.2 Main, System not running

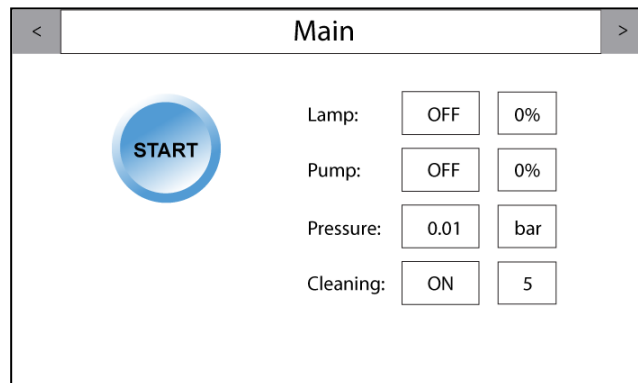

The main screen. System not running.

Right arrow: go to Alarm history screen

Left arrow: go to Information screen

This screen shows the main switch of the system. When the main button has the text *START*, the FluidWorker 100 is ready to be started.

Press the *START* button. Starts the pump and lamp at the same time according to their settings on the Power screen.

Pumps status *ON* and the percentage varies between 0-100% during priming

Lamp status *OFF*: lamp is OFF

Lamp dimming: shows 0%

Pump status: the pump is not running and its pressure is approximately 0 according to pressure sensor

Clean status: The wiper motor works in mode 10 according to its mode table in chapter "Lamp cleaning" on page 60.

A.2.3 Main, System running

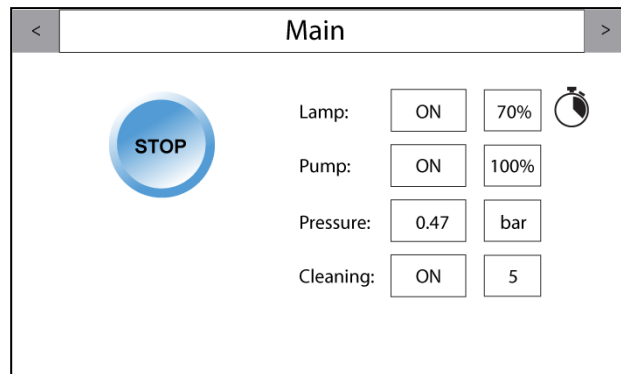

The main screen. System running.

If the main button has the text *STOP* it is waiting to be stopped by the user.

Lamp status ON: lamp is ON (*1).

Lamp dimming: shows the lamp's dimming %.

Pump status: shows if the pump is running or not (*2).

Pressure: shows the current pump pressure, according to pressure sensor.

Clean status: The wiper motor works in mode 10 according to its mode table chapter "Lamp cleaning" on page 60, OFF if mode is 0.

(*1) The ballast is activated if and only if the pump is running to its nominal pressure (>0.15 bar for 5 seconds).

(*2) The priming process is described in a separate chapter.

A.2.4 Main screen, Service

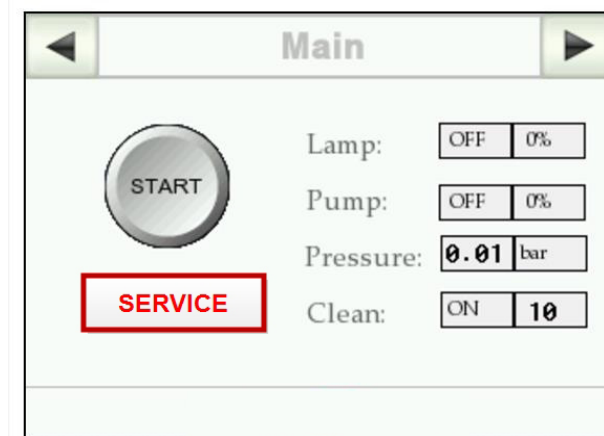

Main screen.

The *SERVICE* button appears on the Main screen when an alarm occurs. Press the *SERVICE* button and read more about the alarm on screen "Alarm History" on the next page. See chapter "Troubleshooting" on page 41 for more information about soft and hard alarms.

A.2.5 Alarm History

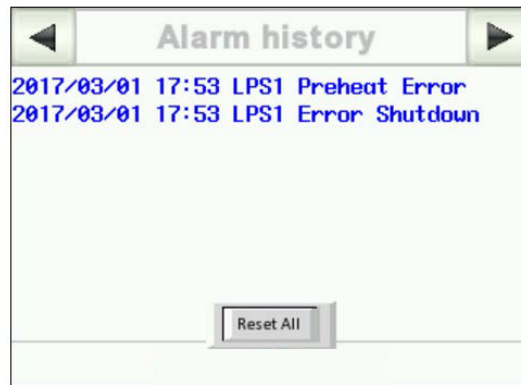

Alarm history

Right arrow: go to Power screen

Left arrow: go to Main screen

NOTE

Alarm history box is blinking red. All the boxes on every page are blinking red when an alarm is ongoing.

On this screen all detected alarms are shown. The normal procedure to handle alarms is:

1. Read the alarm text.
2. Correct the error that caused the alarm.
See the "Troubleshooting" on page 41
3. Press the *RESET ALL* button to reset the alarms.

A.2.6 Power

NOTE

This screen looks different depending on lamp dimming settings. See "Intermittent operation" on page 63.

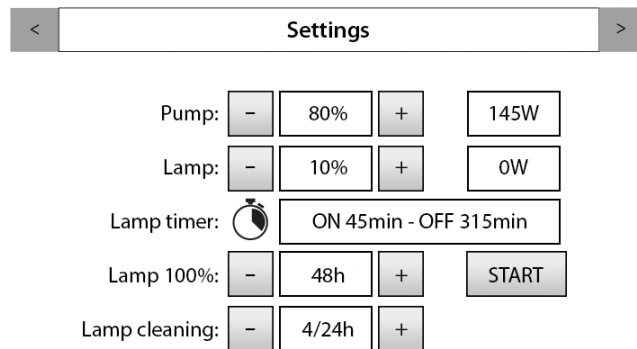

Settings

Right arrow: go to Lamp cleaning screen

Left arrow: go to Alarm history screen

This screen shows:

- the current power consumption of the pump.
- the current power consumption of the lamp.
- the total power consumption of the unit.

Pump control:

- Minus symbol is decreasing the pump in 5% steps down to 70%.
- Plus symbol is increasing the pump in 5% steps up 100%.

Lamp control:

- Minus symbol is dimming the lamp in 10% steps down to 10%.
- Plus symbol is increasing the lamp in 10% steps up 100%.

Lamp 100%:

- Minus symbol is decreasing the amount of hours the lamp works at 100%.
- Plus symbol is increasing the amount of hours the lamp works at 100%.
- When pressing start the lamp will work at 100%, the amount of hours that is chosen and then go back to set point.

A.2.7 Lamp cleaning



Lamp cleaning

Right arrow: Go to Maintenance screen

Left arrow: Go to Power screen

The minus symbol steps down the number of wiper cycles/24h.

The plus symbol steps up the number of wiper cycles/24h.

A.2.8 Maintenance

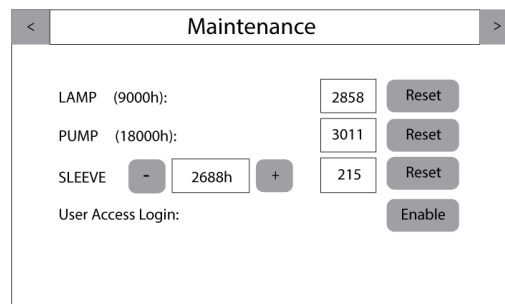

Maintenance

Right arrow: go to Information screen

Left arrow: go to Lamp cleaning screen

This screen gives information about how many hours each component has been running.

When 1000 hours remains of end-of-life, a service message will appear in the alarm list.

NOTE

Pressing Reset is NOT REVERSIBLE.
The counter cannot be recovered.

When the service is completed, the service timers for the lamp and wiper can be individually reset. Press the *RESET* button each time a component is replaced.



Maintenance and confirmation

When the *RESET* button is pushed a pop up window for confirmation will show. In this example the reset button for Lamp has been pressed after lamp replacement.

The login function can be activated by pressing the enable button on the side. A new frame appears asking about the logging code.

A.2.9 Maintenance, User Access

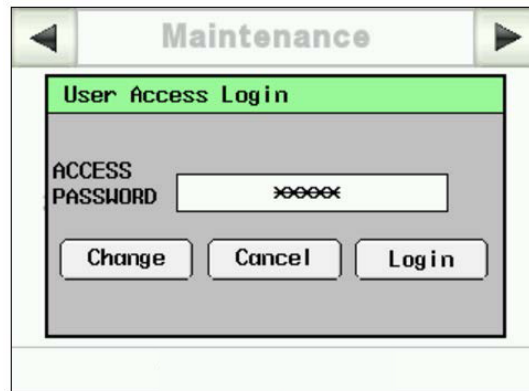

User access

When the user makes any change to the system, and the password is enabled, a login screen is shown.

Password : 1234

After 10 minutes the user is automatically logged out.

A.2.10 Information

NOTE

Due to continuous work of software and hardware, please note the version number on this screen for any communication for identification.

Info	
Date and Time:	<input type="text" value="2018-08-08 08.55"/> <input type="button" value="change"/>
Software version:	<input type="text" value="0.10.14"/>
Bootloader version:	<input type="text" value="1.0.3"/>
Manufacturer:	Wallenius Water Innovation AB www.walleniuswater.com support@walleniuswater.com Tel: +46 8 120 138 10
Technical manual:	www.fw100.se

Information

Right arrow: go to Main screen

Left arrow: go to Maintenance screen

Here is information about software and firmware versions and manufacturer information.

A.3 Intermittent operation

To spare the lamp and reduce heating up a small system, the FluidWorker 100 can be operated in intermittent mode. By running the system intermittently, the UV-dose will also be lowered.

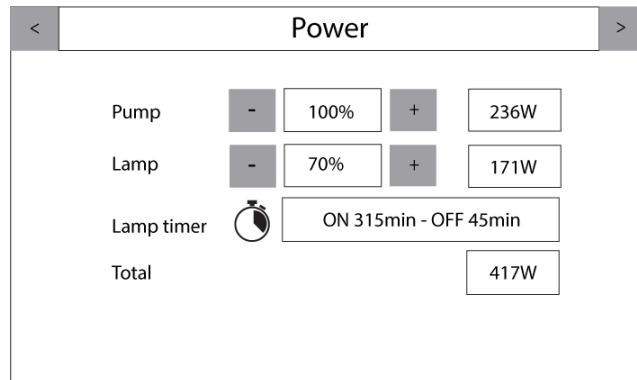

Right arrow: go to Alarm history screen

Left arrow: go to Information screen

Pumps status *ON* and the percentage varies between 0-100% during priming

Lamp status *ON*: lamp is *ON*

Lamp dimming: shows 70%. Use + and - buttons to change dimming degree.

User control of Lamp dimming in FW100

User setting of lamp	Lamp dimming value	Lamp on (min)	Lamp off (min)
100%	100%		
90%	80%		
80%	60%		
70%	80%	315	45
60%	80%	270	90
50%	80%	225	135
40%	80%	180	180
30%	80%	135	225
20%	80%	90	270
10%	80%	45	315

A.4 Electrical drawings

50-0054 FW100 Elconnections -11	65
---------------------------------------	----

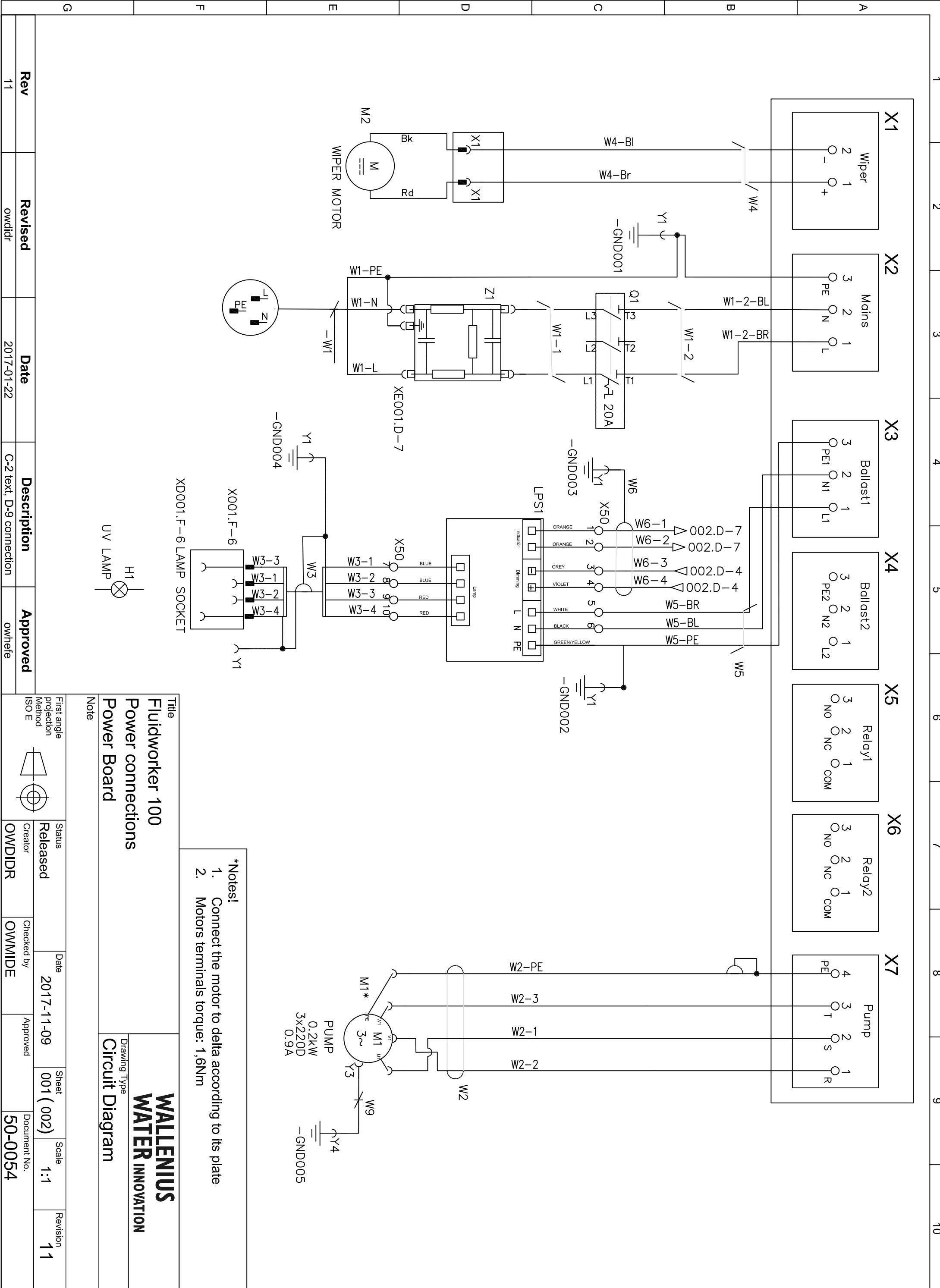

Rev	11	Revised	owdldr	Date	2017-01-22	Description	C-2 text, D-9 connection	Approved	owhefe										
<p>Title Fluidworker 100 Power connections Power Board</p> <p>Drawing Type Circuit Diagram</p> <p>WALLENIUS WATER INNOVATION</p>																			
<p>*Notes!</p> <ol style="list-style-type: none"> 1. Connect the motor to delta according to its plate 2. Motors terminals torque: 1,6Nm 																			
<p>Note</p>																			
Status		Released		Date		2017-11-09		Sheet		001 (002)		Scale		1:1		Revision		11	
Creator		OWDIDR		Checked by		OWMIDE		Approved		Document No.		50-0054							
First angle projection Method		ISO E		Drawing Type		Circuit Diagram													

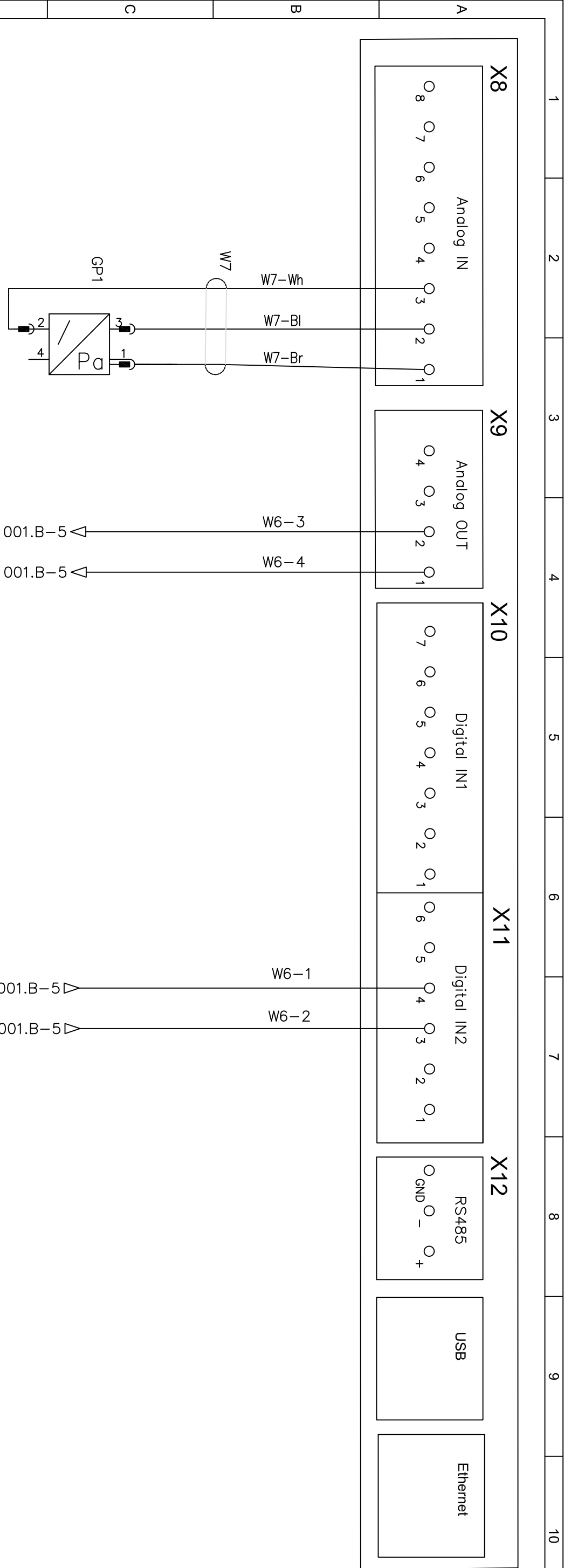

1	2	3	4	5	6	7	8	9	10
<p>Title FluidWorker 100 IO's connections I/O Logic Board</p> <p>Drawing Type Circuit Diagram</p>									
<p>First angle projection Method ISO E</p>					<p>Status Released</p> <p>Creator OWDIDR</p>				
<p>Date 2017-11-09</p>					<p>Checked by OWMIDE</p>				
<p>Approved</p>					<p>Sheet 002 (002)</p>				
<p>Scale 1:1</p>					<p>Revision 11</p>				
<p>Document No. 50-0054</p>					<p>WALLENIUS WATER INNOVATION</p>				

A.5 Maintenance Record

Date	By	Action	Comments/Notes

DECLARATION OF CONFORMITY

We,

Wallenius Water Innovation AB

Franzégatan 3
SE-112 51 STOCKHOLM
SWEDEN

declare under our sole responsibility that the products:

- FluidWorker 100, Part no: 15-01-0113
- FluidWorker 100, Part no 15-01-0117

to which this declaration relates is in conformity with the following laws, standards or other named normative documents:

Low Voltage Directive (LVD) 2014/35/EU:

EN 60204-1:2006	Safety of machinery - Electrical equipment of machines
EN 60204-A1:2009	Safety of machinery - General requirement

Directive of Electromagnetic Compatibility 2014/30/EU:

EN 61000-6-2:2005	Immunity for industrial environments
EN 61000-6-4:2007	Emission standard for industrial environments

Machinery Directive 2006/42/EC:

EN ISO 12100:2010	Safety of machinery - General principles for design
EN 60204-1:2007+ C1:2010	Safety of machinery - Electrical equipment of machines
EN ISO 13949-1:2008/AC:2009	Safety of machinery - Safety-related parts of control systems

Place and date of signature: Stockholm 2019-10-10

Signature of authorized person:



Ulf Arbeus, MD